

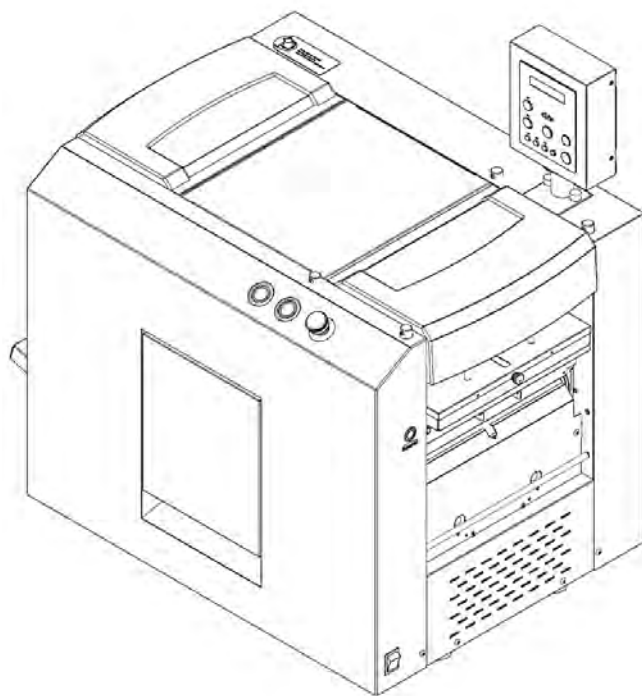

User Manual

MX17000



Contents

Introduction

<i>Introduction</i>	2
<i>Specifications</i>	3
<i>Description of Units</i>	4

Installation

<i>Enclosed Parts</i>	8
<i>Installation</i>	9

Operation

<i>OP Panel</i>	14
<i>Front Button & Remote Control</i>	16
<i>Paper Loading</i>	17
<i>Fan Blower</i>	22
<i>Fold Position Setting</i>	23
<i>Press Gap Adjustment</i>	26
<i>Operation</i>	27
<i>Functions</i>	28

Maintenance

<i>Paper Jam</i>	31
<i>Troubleshooting</i>	32
<i>Cleaning</i>	33

Introduction

Welcome!

Thank you very much for selecting Paitec USA product!

This manual is prepared to provide you with guidelines on how to properly operate and maintain the MX17000. Please read this user manual before operating in order to prevent unexpected malfunction or damage. Please refer to the manual carefully and follow the instruction.

Copyright

Any of the contents should not be copied, re-printed or translated into other languages without Paitec USA approval.

Safety Precautions



Caution: Serious bodily injury or mechanical damage may result from insufficient attention to or incorrect compliance with warning messages with this symbol.

- Do not attempt to disassemble or reassemble the machine. It may cause an electric shock or mechanical problem.
- Disconnect the power immediately if liquid or a foreign object enter the inside of the machine.
- Do not input metal or inflammable material into the inlet.
- This manual is subject to be revised without notice.
- Do not install the machine on the place as below.
 - Near window or places exposed to direct sunlight.
 - Where vibration is detected.
 - Where temperature changes suddenly or poorly ventilated.
 - Places exposed to hot or cold air directly.
 - Not solid enough or weak floor.



Specifications

MX17000 is a heavy duty Standalone / Inline machine with following features - operating speed up to 17,000 sheets / hour (4-step speed adjustable), FRR (Friction Reverse Roller) feeding system and double feed detection by ultrasonic sensor. MX17000 ensures perfect feeding reliability and sealing quality even in high speed operation with Duty Cycle up to 450,000 per month.

Contents	Specifications	Remark
Paper Size	A4 / Letter / Legal	
Input Tray	Up to 1,400 sheets	24#
Speed	Max 17,000 sheets / hour	(11K, 13K, 15K, 17K)
Fold Type	EZ, Z, C, V & Double	
Paper Weight	22-28#	
Infeed Type	FRR (Friction Reverse Rollers)	
Manual Feed	Available	
Double Feed Detect	Detects double feed by Ultrasonic Sensor	
Jam Free	Reverse rollers to clear paper jam	
Printer Inline	Available	*optional
Remote Control	Available	*optional
Weight	242 lbs.	
Dimensions	31" x 21" x 32" [W*L*H]	

Description of Units

1 Front

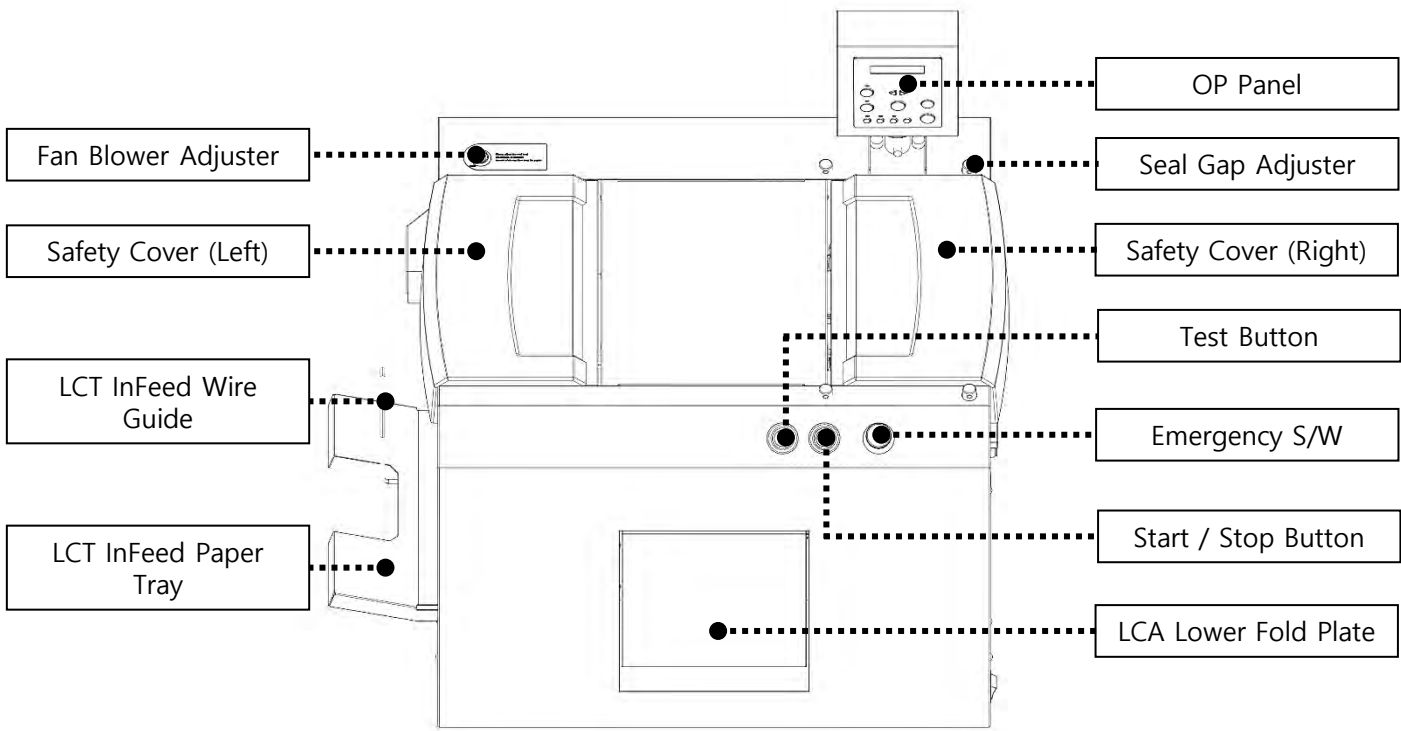

Description of Units

2 Left

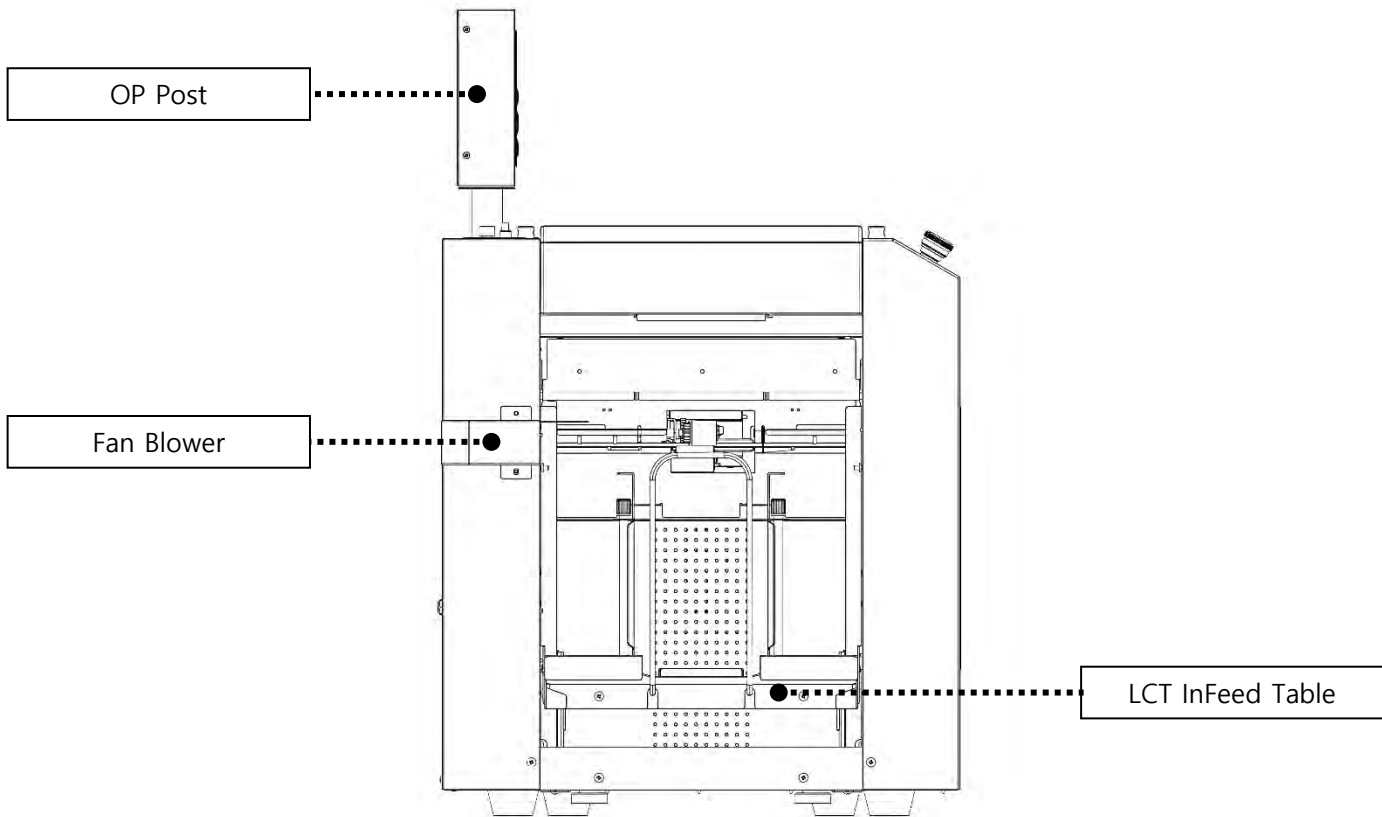

Description of Units

3 Right

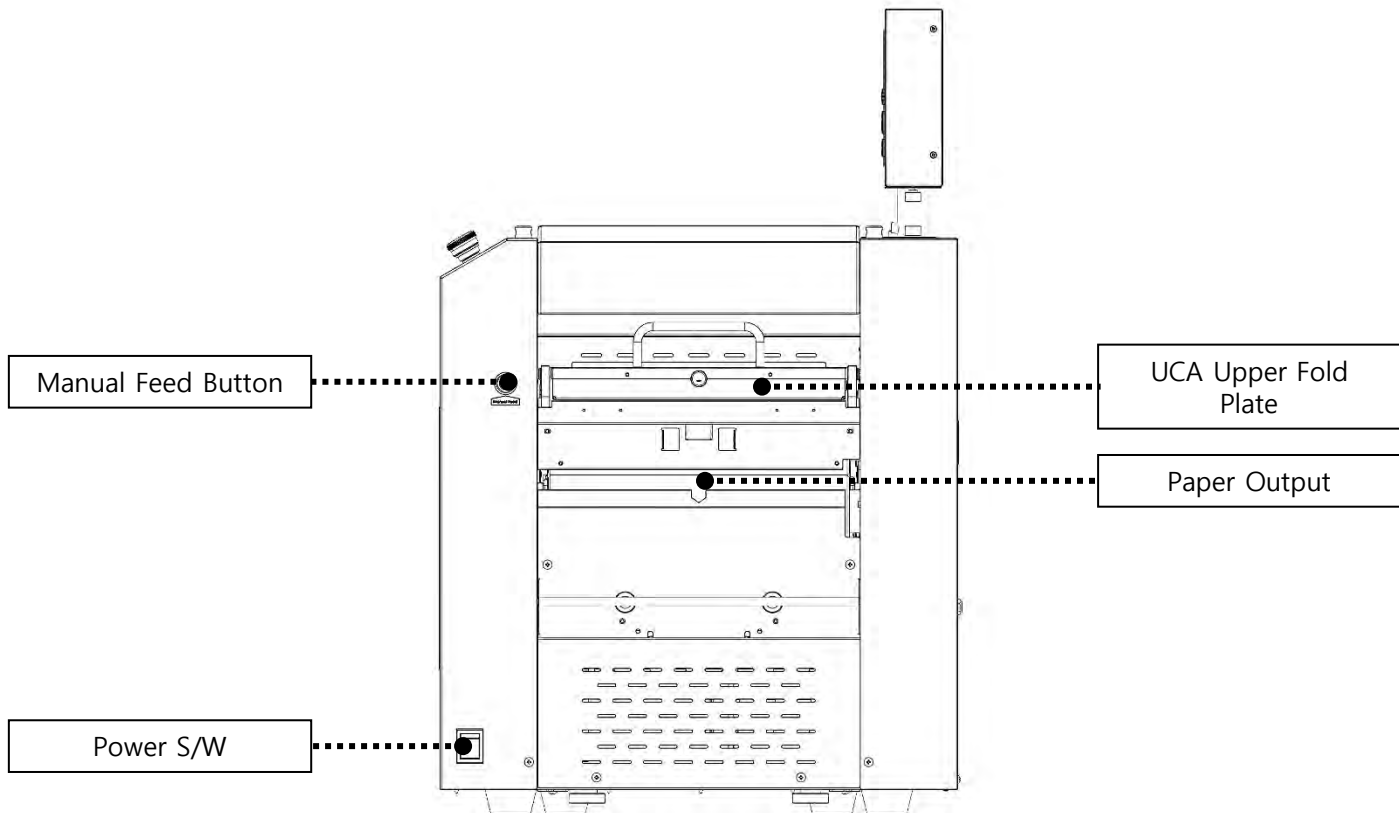

Description of Units

4 Rear

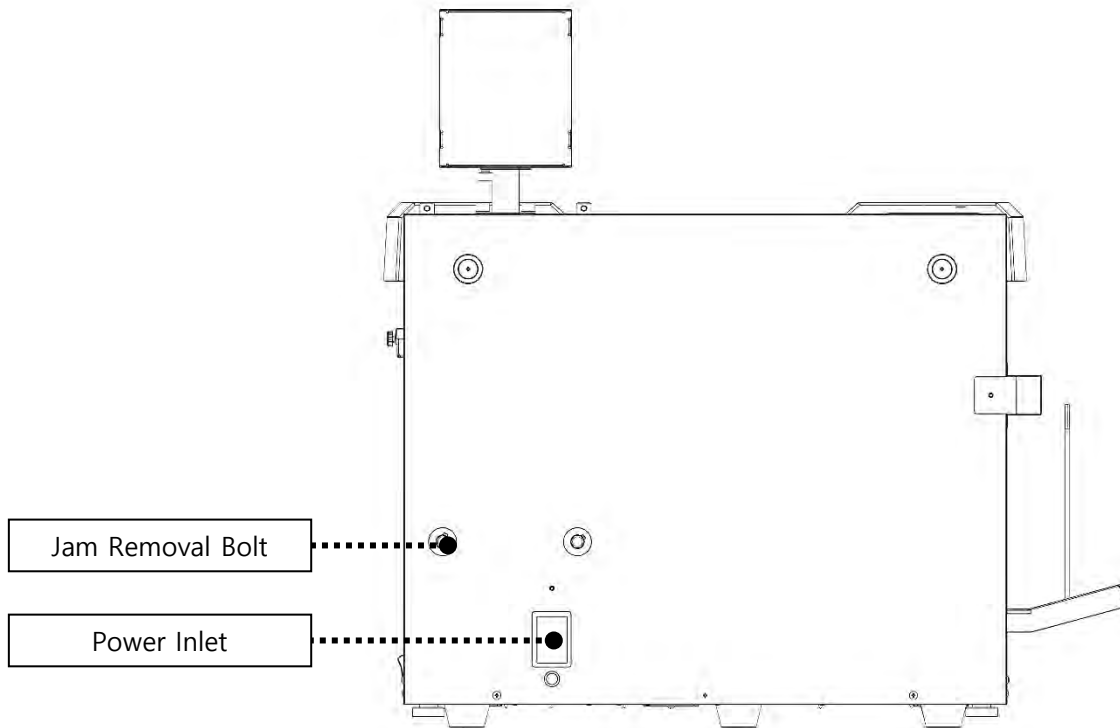

Enclosed Parts

1

Check out all parts are included after unpacking.

● Units



① Main Body

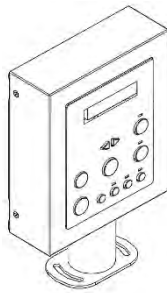

② OP Post

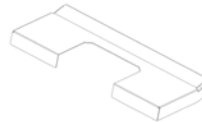

③ LCT Paper Tray Extender



④ LCT Bottom Guide



⑤ V-Fold Guide (optional)



⑥ Power Cable



⑦ Remote Controller (optional)

● Tools & Screws

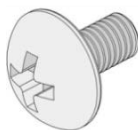

① Screw M4X6L * 2pcs



② Thump Screw * 2pcs



③ Jam Removal Handle

Installation (Cabinet)

- 1 Place the Cabinet in a stable location.

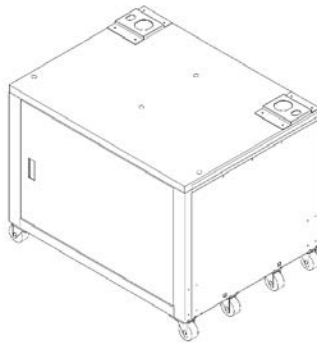

- 2 Place MX17000 Main Body on the Cabinet. Align the Rubber Feet into the Guide Holes.

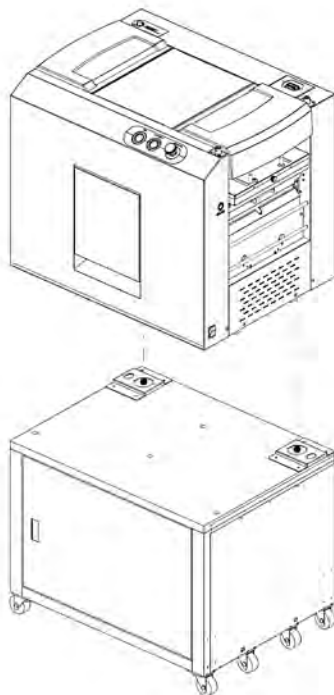

Installation (Table)

3 Slide the Cabinet Brace Guide into Silver Rivets as below.

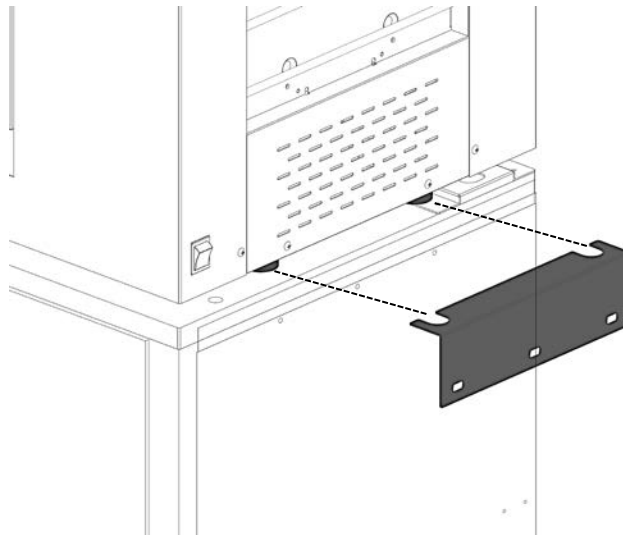

4 Screw the Cabinet Brace Guide (Right) into Cabinet with (3) Black Screws M5*10

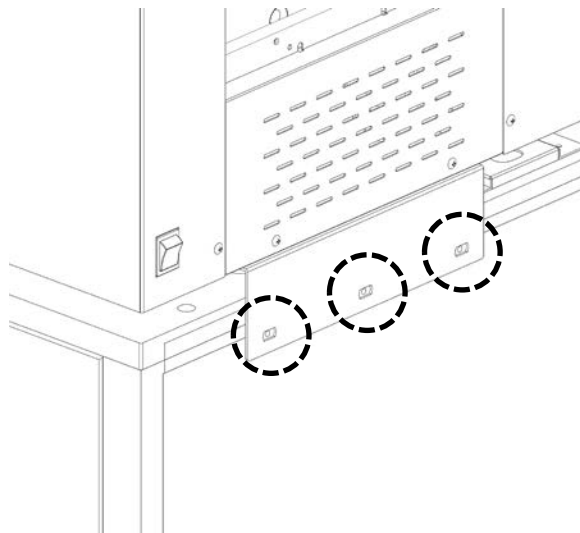

Installation (Table)

- 5 Screw the Cabinet Brace Guide (Left) with (3)Black Screws M5*10 as step 3 & 4.

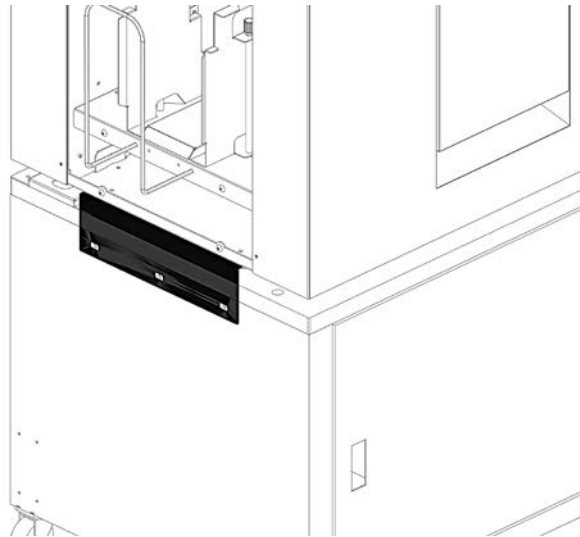

We recommend to install the MX17000 on the optional Cabinet. If not, you must place the MX17000 on stable table since MX17000 is a heavy machine.

Installation (Main Body)

- 1 Fix the (LCT) Paper Tray Extender on the (LCT) Feed Table of machine with (2) screws (M4X6L)

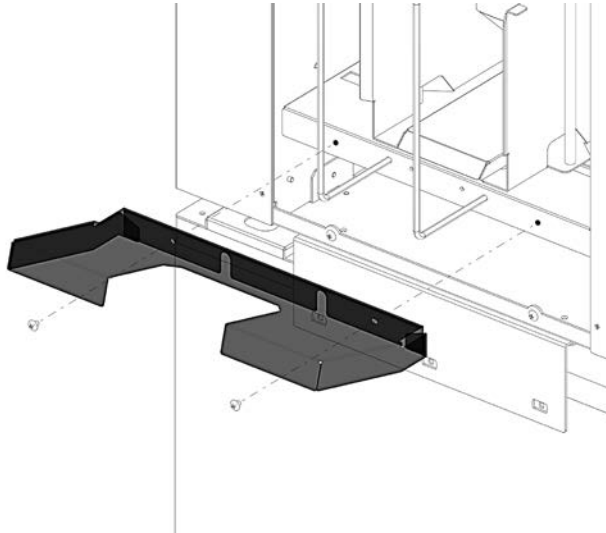

- 2 Connect OP Post Harness Connector (2 pcs) to Main Body as below.

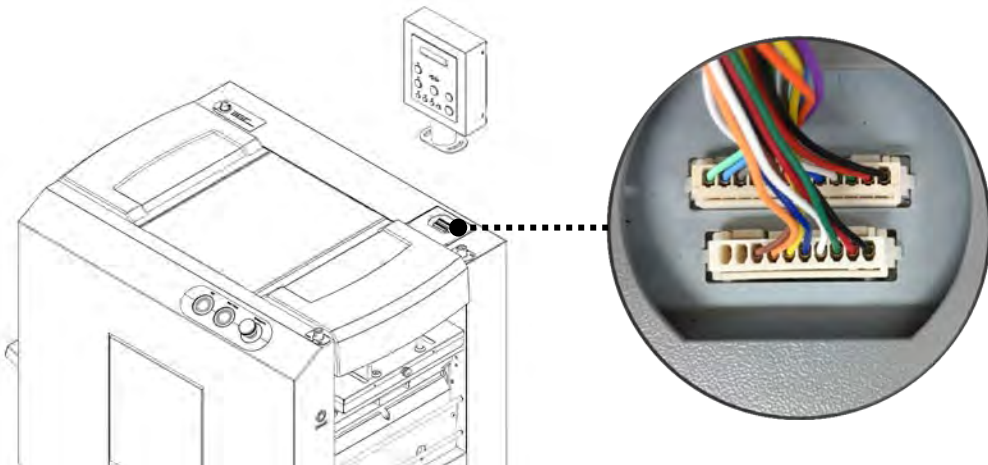

Installation (Main Body)

- 3 Fix the OP Post with Hand Screw (2 pcs)

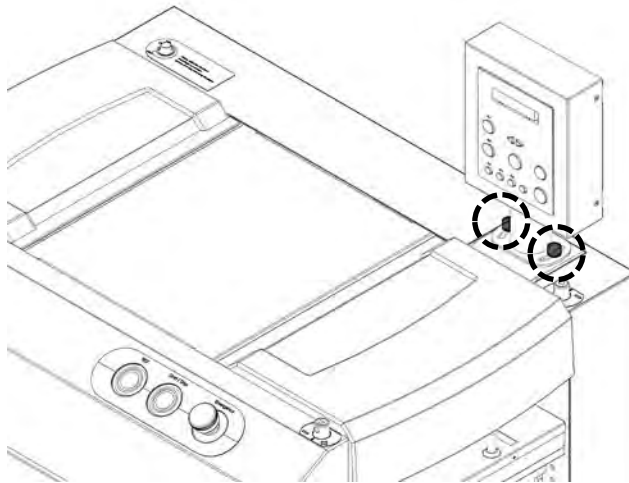

- 4 Install Conveyor or Vertical Stacker into the machine as detailed in the respective Manual.

OP Panel

1 OP Panel Display

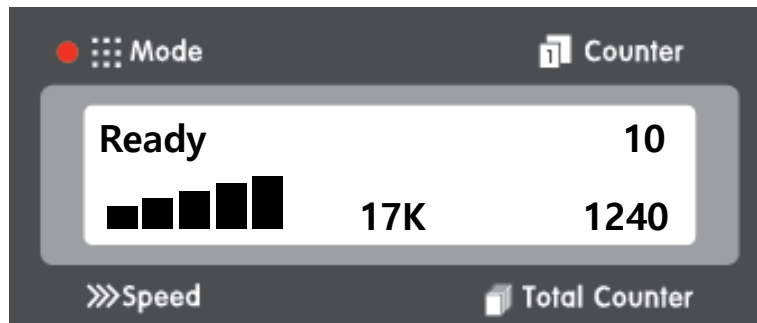

- ① Mode: Machine setting and working condition.
- ② Speed: Operation speed (adjustable, 11K / 13K / 15K / 17K)
- ③ Counter: Counter of current job. (resettable)
- ④ Total Counter: Counter of total operation. (non-resettable)

OP Panel

2 OP Panel Functions

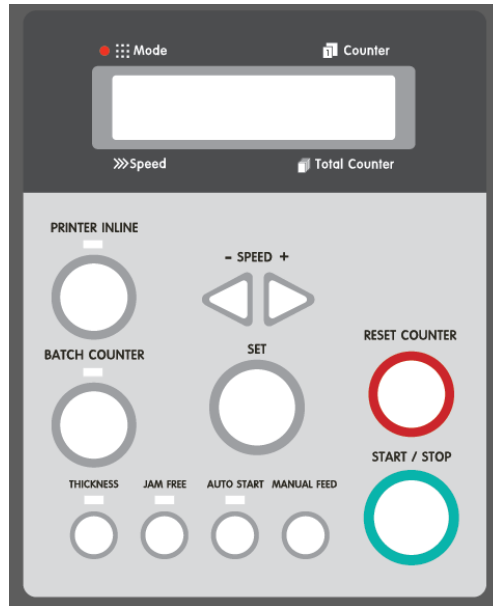

- ① Start / Stop: Press this button to Start & stop the machine; To Exit after programming setup and To Stop the Feed Table (LCT) while moving down.
- ② Set: Sets and stores the selected function.
- ③ Printer Inline: Activate / deactivate Inline function.
*To use Inline operation, you need inline kit (optional) & compatible printer.
- ④ Batch Counter: Enables you to set the number of forms that you wish to process in batch.
- ⑤ Speed (◀▶): Selects + or – to increase/decrease the speed (while machine is in stop mode)
- ⑥ Reset Counter: Clears the current job count on the display.
- ⑦ Thickness: Press to turn on or off the double detections using Ultrasonic Sensor Technology.
- ⑧ Jam Free: Assist with removal of paper jam at folding rollers or seal rollers.
- ⑨ Auto Start: Re-starts the process after selected time when the job reaches preset count.
- ⑩ Manual Feed: Use for single-sheet operation manually.

Front Button & Remote Controller

1

Front Button

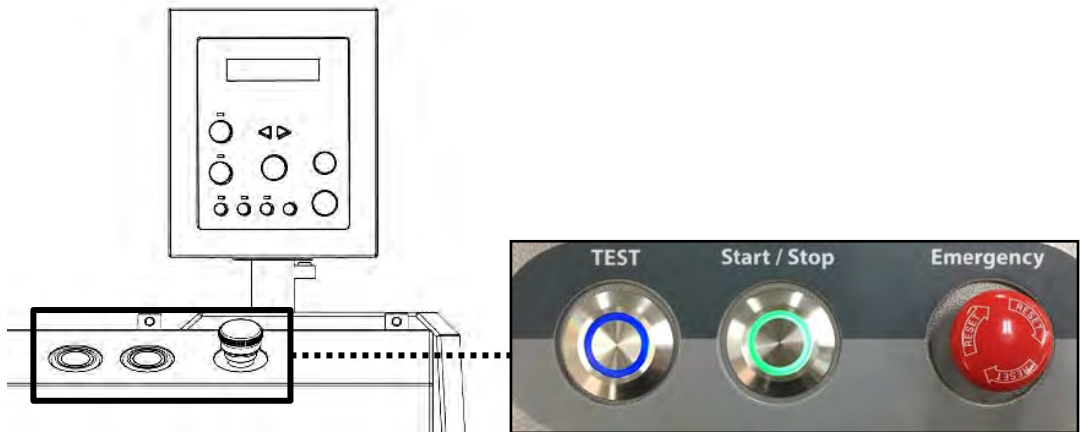

- ① Test: Test Button for single-sheet operation.
- ② Start / Stop: The same function of Start / Stop on the OP Panel.
- ③ Emergency: Stop operation of machine for emergency situation.

2

Remote Controller

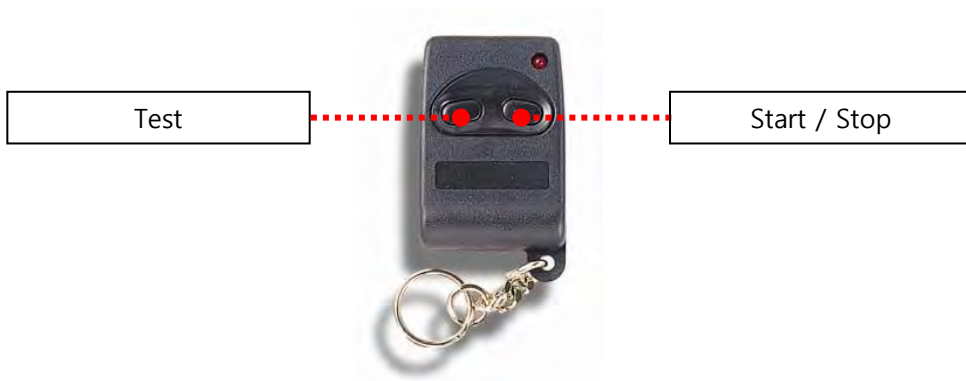

MX17000 is able to be operated by remote controller with Test & Start / Stop button.

Paper Loading

1 Paper Size

① MX17000 is able to handle the following size of forms.

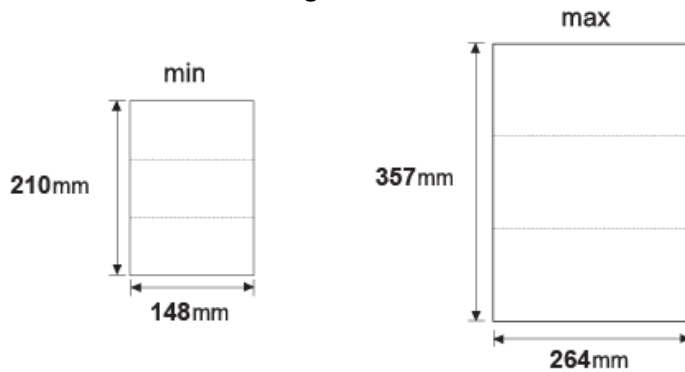

⚠ If you use paper that is larger than or smaller than the specified paper, you may experience problems with the machine, such as paper jams.

2 Paper Loading

① Before loading the forms onto the machine, please make sure all forms are aligned and fanned. Please refer to the images below.

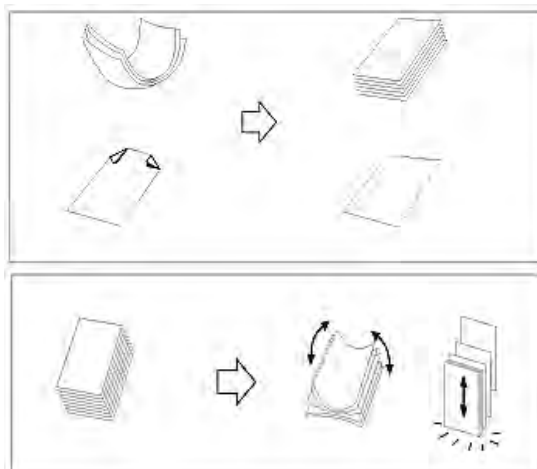

Paper Loading

3 To prevent paper bending when loading a big stack of paper in the (LCT) Feed Table, install the LCT Bottom Guide.

① Align the LCT Bottom Guide at the top of the (LCT) Feed Table as below.

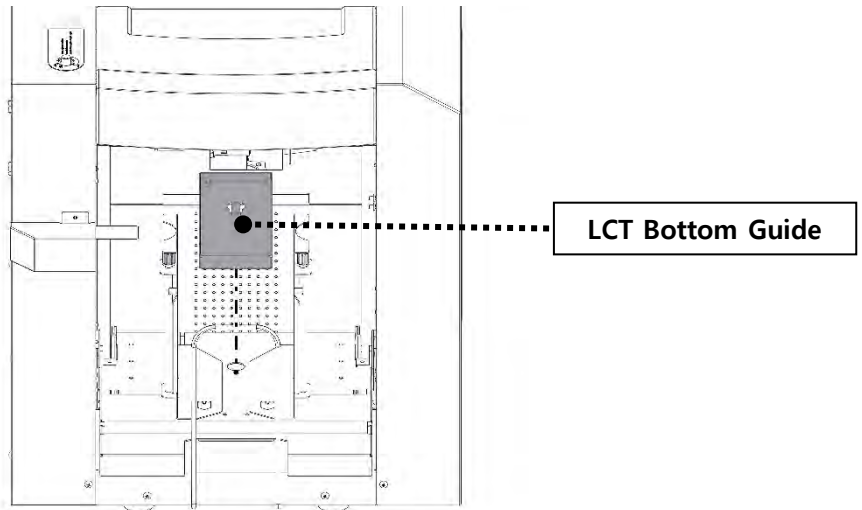

② Insert the LCT Bottom Guide into the (LCT) Feed Table Hole as below.

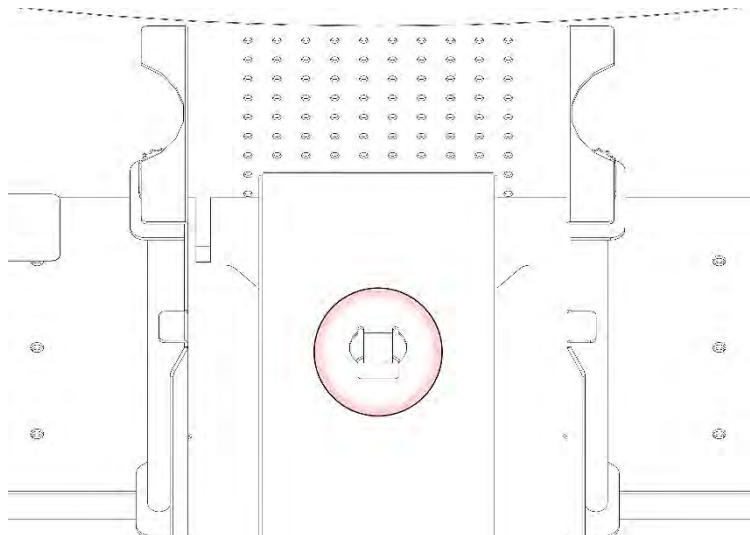

Paper Loading

4 Adjust the Feed Table (LCT) Guide and Feed Table (LCT) Wire Guide positions to match the paper size.

- ① Rotate the LCT Fix Knob to CCW to unlock.

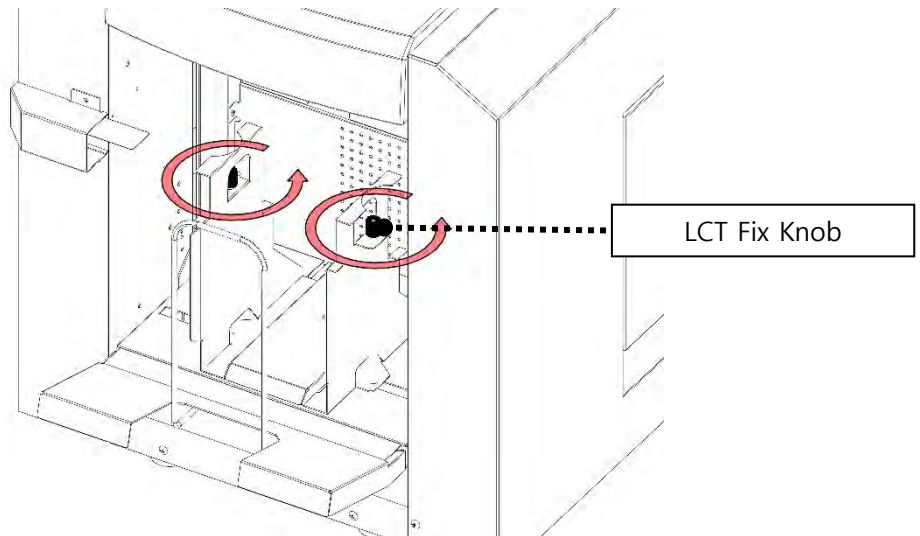

- ② Move the LCT Guide to adjust to match the paper size. After adjustment, rotate the LCT Fix Knob to CW to lock.

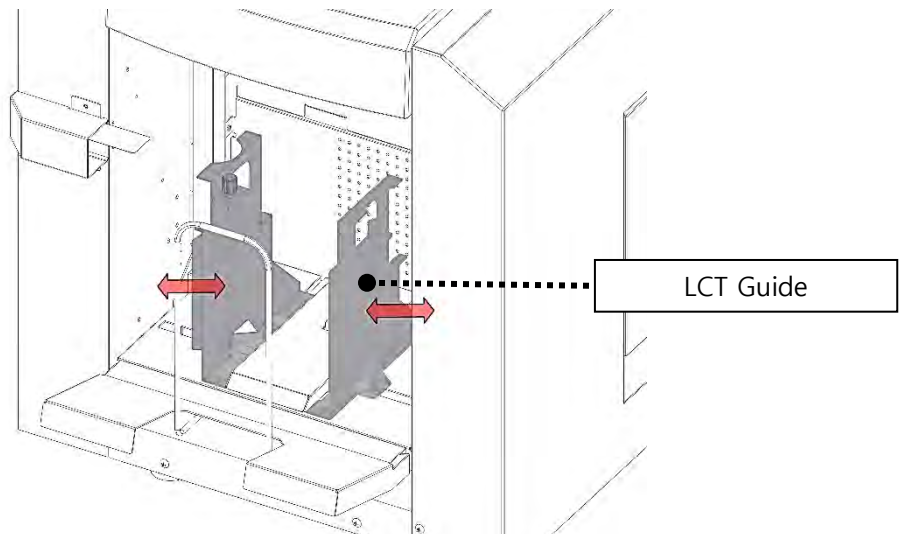

Paper Loading

4 Adjust the LCT Guide and LCT Wire Guide positions to match the paper size.

③ Adjust the LCT Wire Guide position to match the paper size.

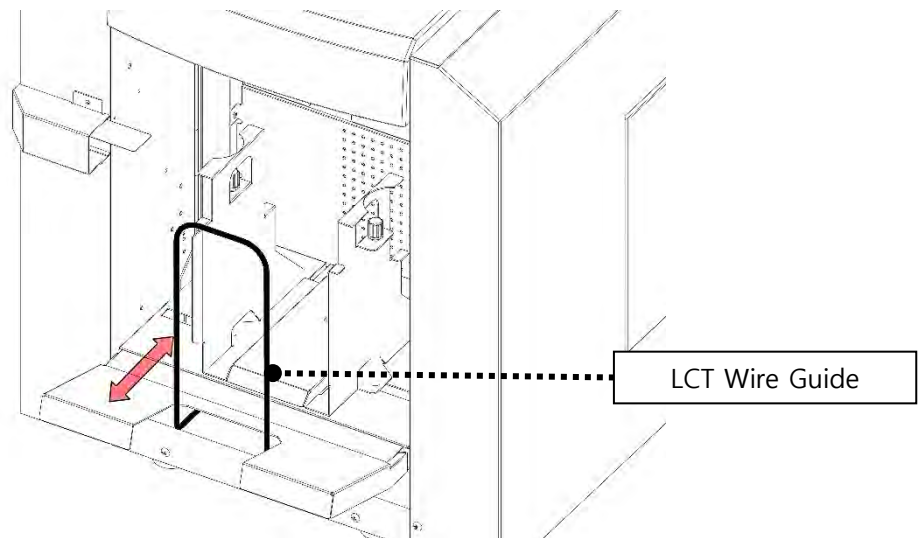

The paper must be positioned at the center of the Feed Table (LCT) as accurate as possible for smooth feeding.

Paper Loading

5 After adjustment, open the Safety Cover (Left) and load the paper on the Feed Table (LCT).

① Open the Safety Cover (Left) or no paper detected on the Feed Table (LCT), Feed Table (LCT) goes down for paper loading. When the (LCT) lower to the bottom, load the paper on the LCT

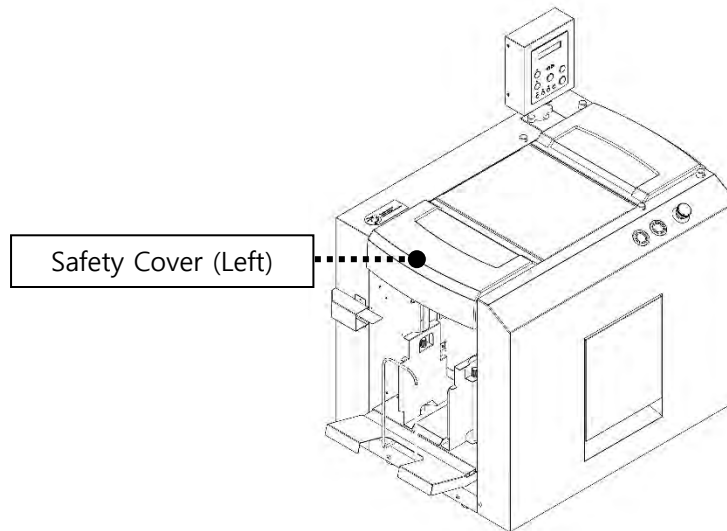

② Close the Safety Cover (Left) after loading the paper. The Feed Table (LCT) automatically goes up.



Check that there is no foreign matter (adhesive, staple) on the paper before feeding. It may cause a malfunction and damage on the machine.



If the paper is not in good condition (paper curl, wet ink, etc.), it may cause miss-feeding or paper jam.

Fan Blower

- 1 The MX17000 has a Air blower to the Feed Table (LCT) to assisted paper feeding. Use the Fan Volume Control Knob to adjust the fan speed.

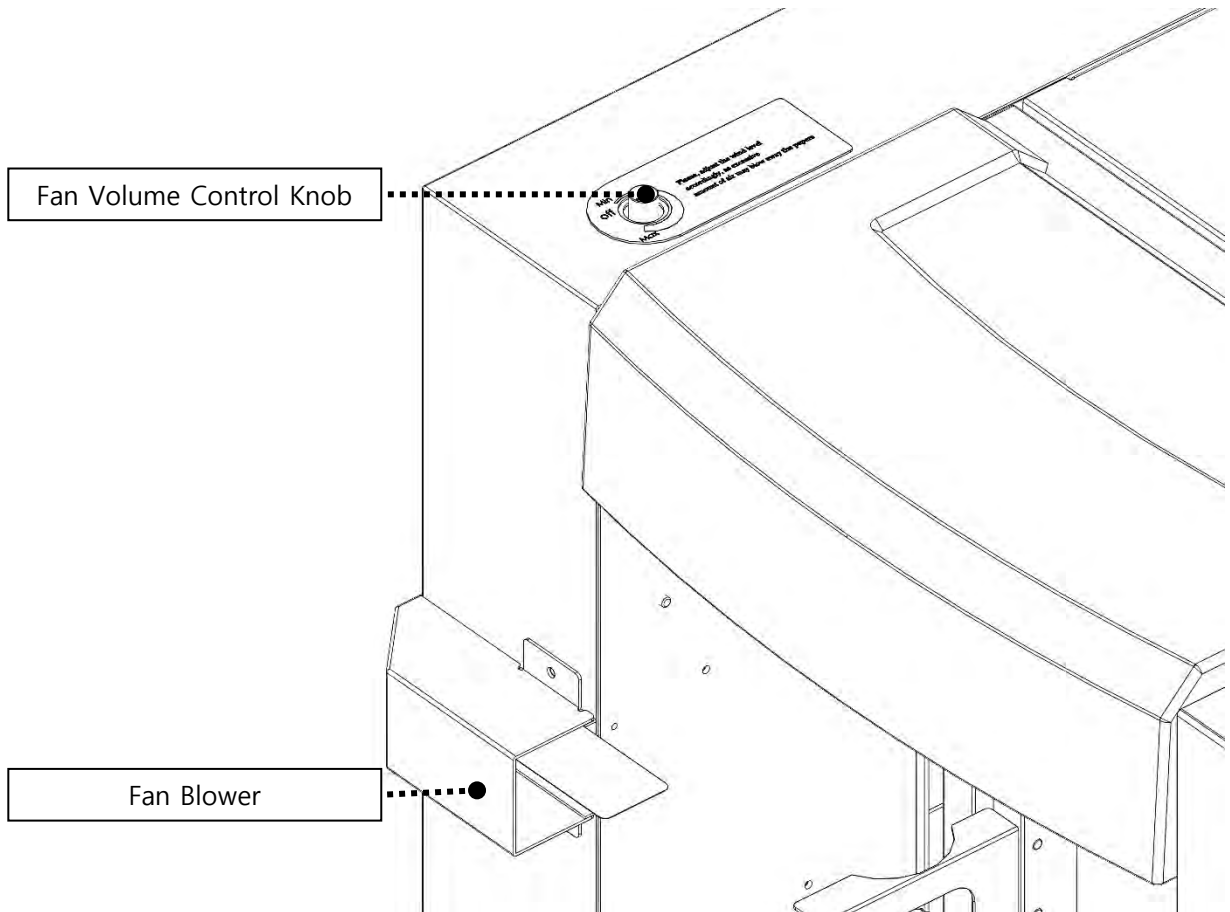

If the fan speed is too high, the paper may separate too much for paper feeding. Adjust the fan speed according to the paper weight.

Fold Position Setting

1

UCA (Upper Cassette, 1st fold) Fold Position Setting

① Open the Safety Cover (Right) and pull out the UCA as below.

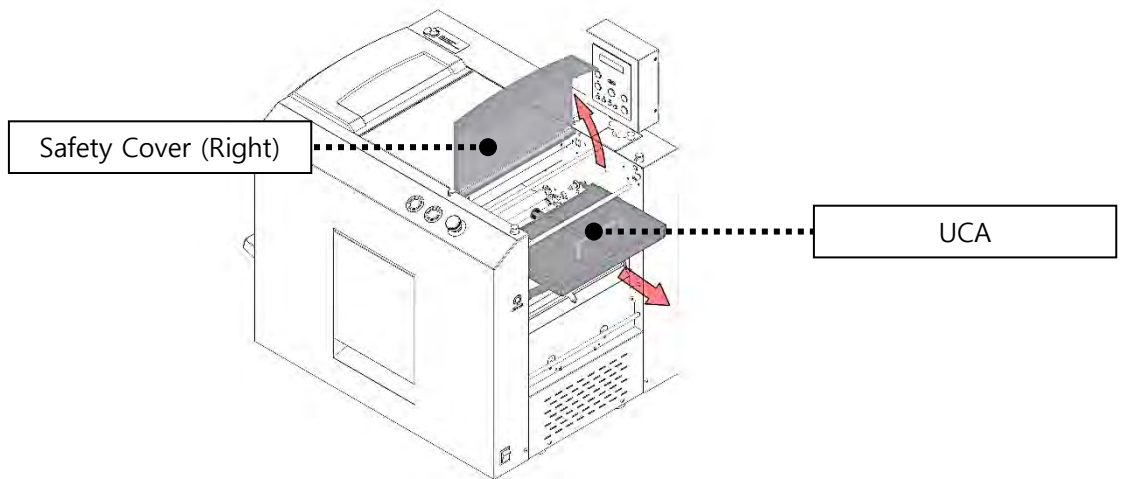

② Rotate the Locking Knob counter clockwise to unlock, then adjust the fold position with Fold Position Knob. Lock the Locking Knob after adjustment.

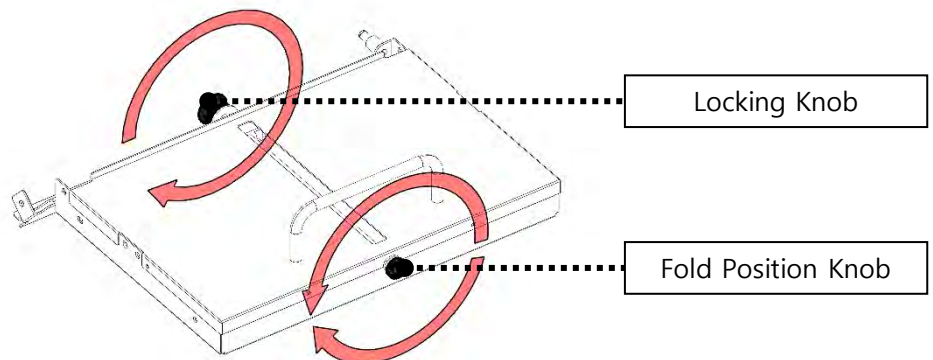

Fold Position Setting

2 LCA (Lower Cassette, 2nd fold) Fold Position Setting

- ① Pull out the LCA as below.

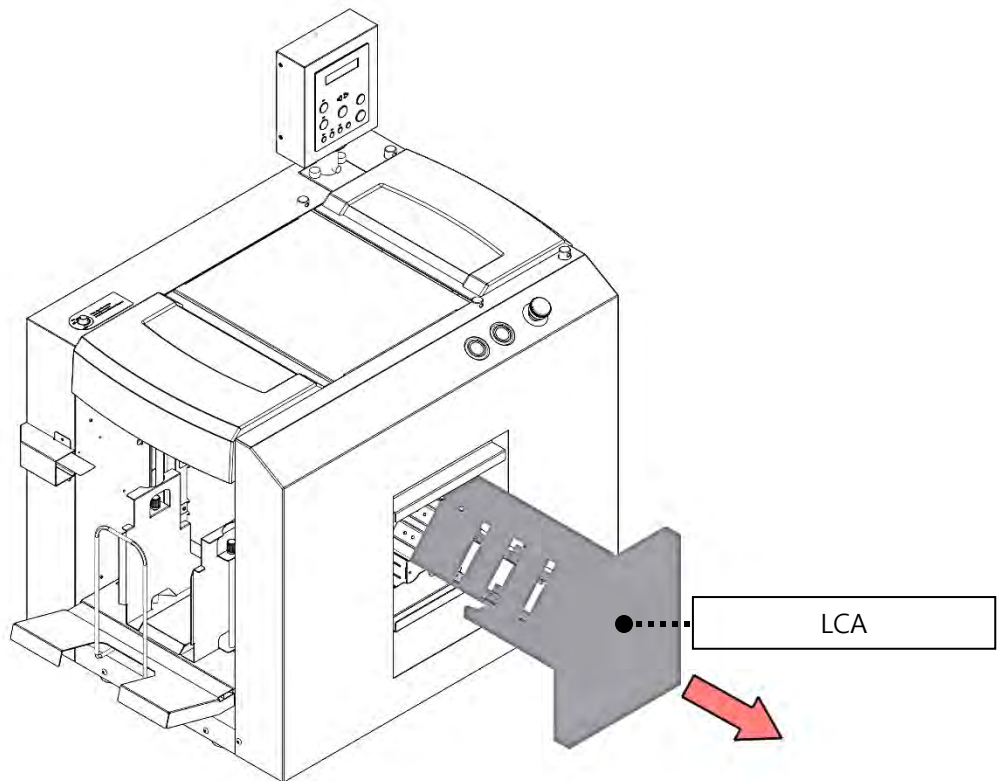

Fold Position Setting

2 LCA (Lower Cassette, 2nd fold) Fold Position Setting

- ② Rotate the Locking Knob to CCW to unlock

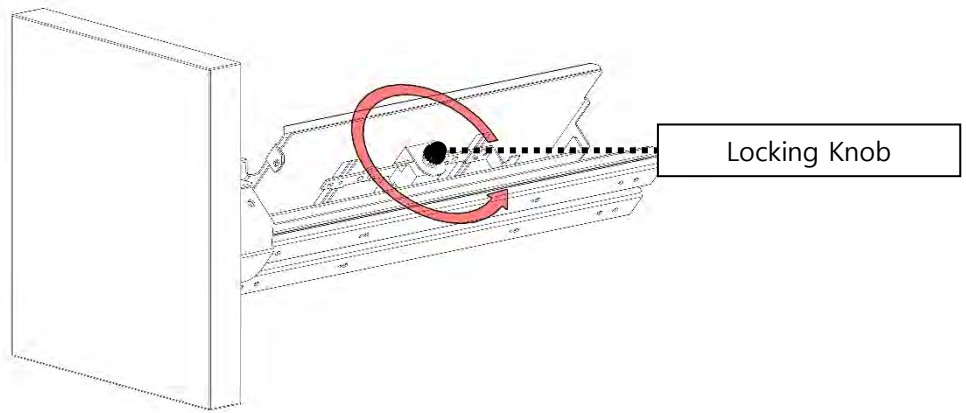

- ③ Adjust the fold position with Fold Position Knob. Lock the Locking Knob after adjustment.

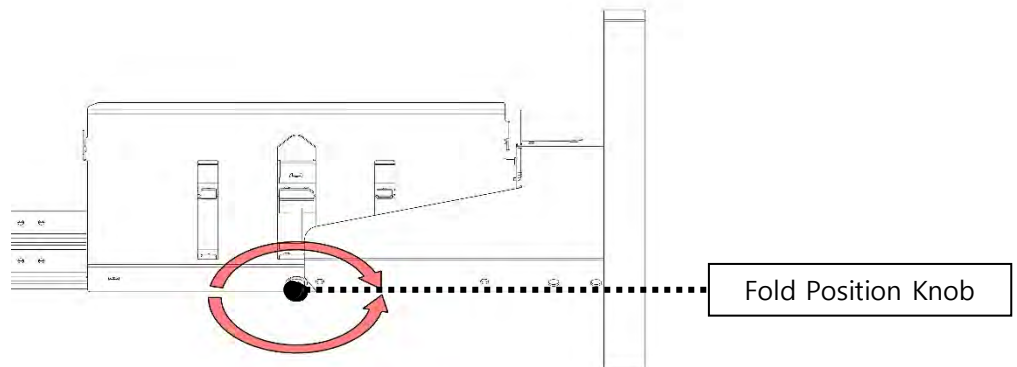

Press Gap Adjustment

1

MX17000 is able to be adjusted the Press Gap by adjusters (2 pcs)

- ① "+" means increasing the press gap
- ② "-" means decreasing the press gap
- ③ Put a tool into the Adjuster & rotate CW / CCW to adjust the gap

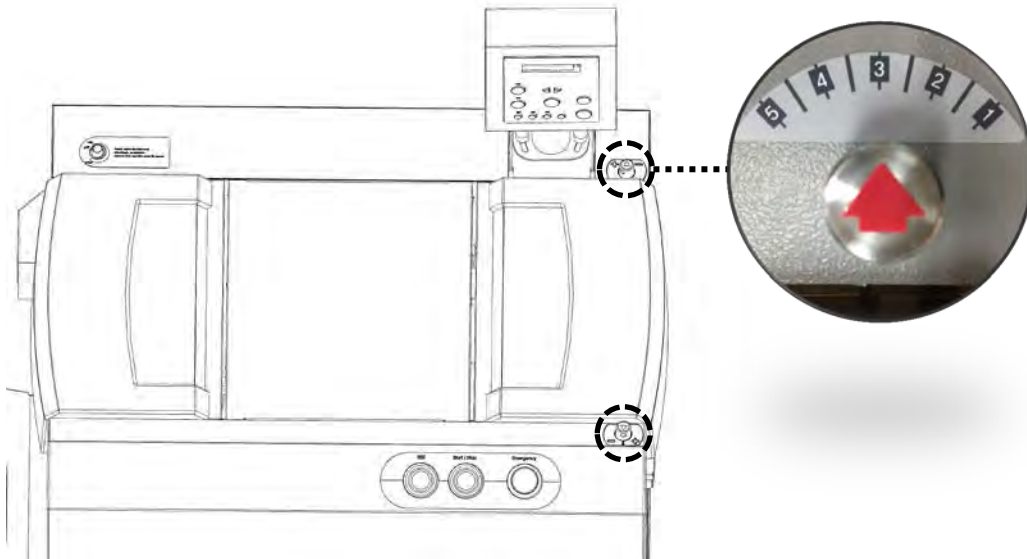

You must set the same value ("+" or "-") on upper & lower Press Gap Adjuster.



We recommend you to keep the default position of Press Gap Adjuster. If there is an issue to change the gap, please contact local dealer or service company to adjust the Press Gap with engineer.

Operation

1

Load the paper on the Feed Table (LCT).

2

Adjust the fold position of UCA / LCA as your desire fold type.

3

Press the Thickness button on the OP Panel to detect the thickness of the paper.

① The MX17000 has an ultrasonic sensor to detect paper thickness & prevent double feeding.

When you press the Thickness button, a sheet of paper is fed and automatically detects the paper thickness.

② When the double detection function is activated, the Thickness lamp is turned on
Pressing the button again will turn off the lamp and double detection will be disabled.

4

Press Start / Stop button for operation

① Operation will continue to run until finishing all of the paper loaded on the Feed Table
(when Batch Count / Auto Start function is activated, it depends on the amount of count setup)

② Press Start / Stop button during machine operation, the machine will stops.



If an emergency occurs during operation, press the emergency switch on the front of the unit to stop the machine.

Functions

1 Batch Count

You can set the Batch Count of a job to be run. For example, if you set the count on 100, machine will stop operating when the job reaches 100. Press Start/Stop button again, machine will start to finish another 100.

- ① Press Batch Count button and the LED will light on
- ② Select job volume by using ◀▶ button.
 - * Press the button on by one, count will change by 1 and if you press for more than one second, the count will change by 10/second.
 - * Press Batch Count button, the count will change 50~100.
- ③ Press Set button and check the number displayed on the panel.
 - * You can set the counter up to 500 sheets.

2 Auto Start

Auto Start: this function allow you to setup the time for the machine to be pause (Time Interval) at the end of each batch and Start again for the next batch.

- ① Set the Batch Count first. Auto Start is only available when Batch Count is activated.
- ② After pressing Auto Start, "Time Interval" will be shown on the OP. Set the interval time with ◀▶ buttons.
- ③ Press Set to save the value. (Max 99 seconds)
- ④ Machine will run up to the number Batch Count as setting. Pause at (Time Interval) as setting & Start again automatically.
- ⑤ If you turn off and on the machine, you have to set the function again.

Functions

3 Thickness

The Thickness function detects the thickness of the paper through the ultrasonic sensor to prevent serious paper jams due to double or multi feeding.

- ① Press the Thickness button, 1 sheet is fed to detect the thickness of the paper.
- ② When the double detection function is activated, the Thickness lamp is turned on
Pressing the button again will turn off the lamp and double detection will be disabled.
- ③ When the machine is detecting double feeding while using the function, the machine will stop operating with the message "Double Feed".



If you turn Off the machine or change the paper type, be sure to reset the paper thickness after turn On by pressing the Test button.

4 Manual Feed

Manually handling single sheet job for damaged paper & small amount of work.

- ① Holding down the Manual Feed button on OP Panel & Feed a pre-fold form in the entry slot on the exit path of the machine.
- ② Press the other Manual Feed (red) button on the side of the front cover. The pre-fold form will enters into the press rollers for sealing and is ejected.
- ③ Keep holding down both Manual Feed button until the form is rejected on the exit path.



Be careful not to get your hands caught in the press roller inside the Machine while using Manual Feed Function.

Functions

5 Jam Free

In case the paper is jammed at folding or press rollers, machine will stop with error message. If you press Jam Free button, machine will try to reverse direction to release the jam in the rollers then you will have to remove by hand through the top cover. Note: The feeding unit motor will not run during this operation.



The Jam Free feature does not resolve all paper jams. In the event of a serious paper jam, place the Jam Removal Tool in the Jam Removal Hole on the back of the machine to remove the paper jam.

※ How to manually clear a jam by using the jam removal tool, turn in the direction of arrow.

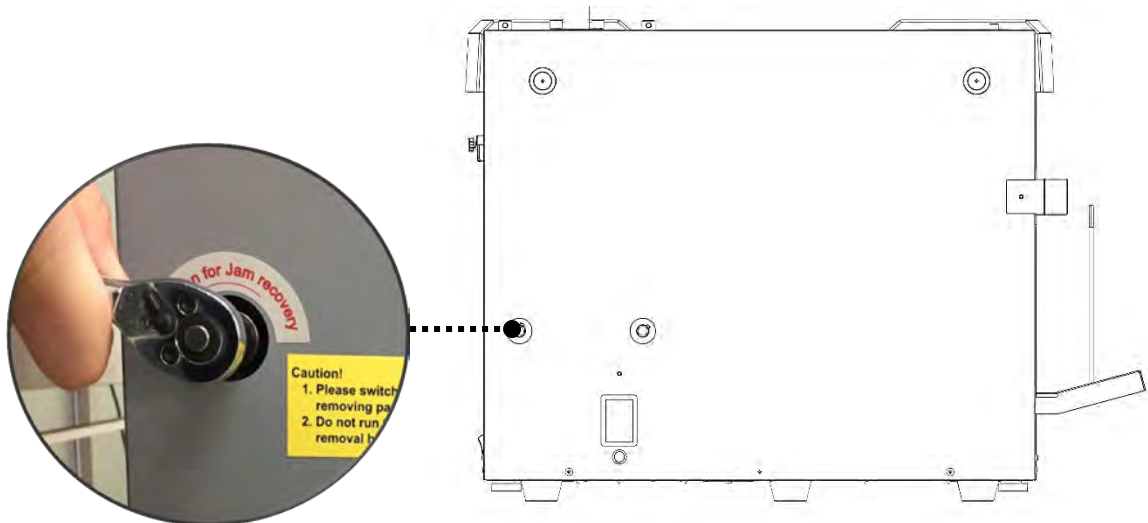

Be sure to remove the tool before operating the machine.

Paper Jam Remove Options

1

UCA Paper Jam (Upper Fold Plate Cassette)

- ① Open Safety Cover (Right)
- ② Pull out the UCA & remove the paper jam.

2

LCA Paper Jam (Lower Fold Plate Cassette)

- ① Pull out the LCA.
- ② Remove the paper jam.

3

Press Roller Paper Jam

- ① Try to remove the jam by using the Jam Free function.
- ② If the jam is not cleared by using the Jam Free function, please use the jam removal tool to manually remove the jam.



Turn off the power before remove any jams.

Trouble Shooting

1

No Power

- ① Check whether the power cable is properly connected.
- ② Check the power supply.
- ③ Check if the "RED" Emergency Button is pushed.

2

Incorrect Folding

- ① Check the fold setting on the two fold plates (Upper and Lower Cassette).
- ② Check the direction of paper on the LCT (Feed Table).

3

Power On, but No Start

- ① Check the "Mode" on the OP Display is "Ready" condition.
- ② Check out the Safety Covers (left & right) are closed.
- ③ Check out the LCA / UCA is closed.
- ④ Check out if there is a paper jam inside of the machine.

4

Frequent Double or Multiple Sheet Feeding

- ① Check the condition of Infeed Roller Set. Try to clean them or replace all three rollers all at once if they are worn out.
- ② Check whether the adhesive on the sealer paper is too thick or too tacky.
- ③ If the paper is curled or the ink does not dry out after printing, the paper may not be separating properly.
- ④ After power On or after changing the form, Press Thickness Button to re-calibration.



If the errors keep occurring, please contact the local dealer or service company.

Cleaning

1 Infeed Roller Set

The feeding rollers consist of three different rollers as Pickup / Feed / Separation Roller. If the rollers are contaminated or worn out, feeding failures might occur. Please clean the rollers periodically. If they are worn out, replace all three of them at once.

Note: Using Denatured alcohol. Do not use regular roller cleaner solutions.

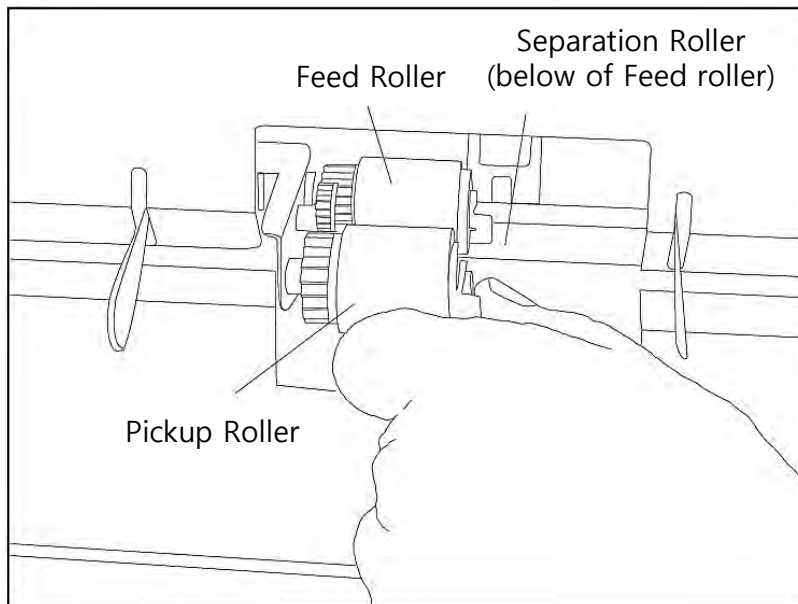

- ① Remove the Snap-Ring which is holding the roller on the shaft.
- ② Remove the roller & clean by a soft clothing with Denatured alcohol.
- ③ After cleaning, put the roller back on the shaft and reattach the Snap-Ring.

Cleaning

2 Fold Roller

Since Pressure seal forms leave paper dust, ink and toner residues, it is very important to occasionally clean the surface of each fold roller to maintain its best condition for better performance.



- ① Open the Safety Cover (Right) & pull out UCA. (Upper Fold Plate Cassette)
- ② Clean each roller by a soft clothing with Denatured alcohol. Rotate the roller to clean all surface of roller.
- ③ Close the UCA & Safety Cover (Right).



Please do not use any other substance when cleaning the surface of the fold rollers as it may damage the Polyurethane.

