

IDEAL 4215



- Sicherheitshinweise • Safety precautions
- Consignes de sécurité • Veiligheidsvoorschriften
- Misura di Sicurezza • Normas de Seguridad
- Säkerhetsföreskrifter • Turvallisuusohjeita • Sikkerhetsforskriftene
- Środki bezpieczeństwa • Меры предосторожности

IDEAL 4215



- D** Bitte lesen Sie vor Inbetriebnahme der Maschine unbedingt diese Betriebsanleitung und beachten Sie die Sicherheitshinweise. Die Betriebsanleitung muss jederzeit verfügbar sein.
- GB** Please read these operating instructions before putting the machine into operation and observe the safety precautions. The operating instructions must always be available.
- F** Nous vous prions de lire attentivement le mode d'emploi avant d'utiliser la machine, et attirons votre attention sur les consignes de sécurité. Les instructions d'utilisation et les consignes de sécurité doivent toujours être disponibles. Les instructions d'utilisation et les consi.
- NL** Leest u voor de ingebruik name van het apparaat a.u.b. deze gebruiksaanwijzing goed door en neemt u de veiligheidsinstructies n acht. De gebruiksaanwijzing en de veiligheids-voorschriften moeten altijd binnen handbereik zijn.
- I** Per favore legga questo manuale di istruzione prima di mettere in funzione il distruggidocumenti e osservi le regole di sicurezza. Le istruzioni d'uso devono essere sempre disponibili.
- E** Le recomendamos lea las instrucciones antes de poner en funcionamiento esta máquina y cumpla las normas de seguridad. Las instrucciones de servicio y seguridad deben estar siempre disponibles.
- S** Läs igenom denna bruksanvisning innan ni startar maskinen. Var noga med säkerhetsföreskrifterna. Instruktionsmanualen måste alltid finnas tillgänglig.
- FIN** Lue nämä käyttö-ohjeet läpi ennenkuin käynnistät laitteen !
Noudata turvaohjeita. Käyttöohjeiden on oltava aina saatavilla.
- N** Lees gjennom denne bruksanvisningen før De tar i bruk maskinen Vær oppmerksom på sikkerhetsforskriftene. Operatørmanualen må alltid være tilgjengelig.
- PL** Proszę uważnie przeczytać instrukcję obsługi przed uruchomieniem urządzenia i stosować się do przepisów bezpieczeństwa. Instrukcje obsługi muszą być zawsze dostępne.
- RUS** Пожалуйста, прочитайте инструкцию по эксплуатации перед установкой аппарата, соблюдайте технику безопасности. Инструкция по эксплуатации должна находиться в доступном для пользователя месте.
- H** A gép üzembe helyezésé előtt figyelmesen olvassa el a kezelési utasitást és tartsa be a biztonsági előírásokat. Kezelési utasításnak mindig elérhetőnek kell lennie.
- TR** Lütfen makineyi çalıştırmadan önce bu kullanma talimatlarını dikkatli bir şekilde okuyunuz ve belirtilen güvenlik önlemlerine uyunuz. Kullanma Talimatları her zaman kullanıma hazır olmalıdır.
- DK** Før installation af maskinen bedes De venligst læse brugervejledningen brugervejledningen og være opmærksom på sikkerhedsanvisningerne. Brugervejledningen skal altid være tilgængelig.
- CZ** Prosím přečtěte si instrukce k obsluze a dodržujte bezpečnostní upozornění. Návod k obsluze musí být vždy dostupný.
- P** Por favor leiam o manual de instruções antes de colocar a máquina em operação e vejam as precauções de segurança. As instruções de operação deverão estar sempre disponíveis.
- GR** ΠΑΡΑΚΑΛΩ ΔΙΑΒΑΣΤΕ ΤΙΣ ΟΔΗΓΙΕΣ ΧΡΗΣΕΩΣ ΚΑΙ ΤΙΣ ΠΡΟΦΥΛΑΞΕΙΣ ΑΣΦΑΛΕΙΑΣ ΠΡΙΝ ΒΑΛΕΤΕ ΤΟ ΜΗΧΑΝΗΜΑ ΣΕ ΛΕΙΤΟΥΡΓΙΑ. ΟΙ ΟΔΗΓΙΕΣ ΧΡΗΣΗΣ ΠΡΕΠΕΙ ΝΑ ΕΙΝΑΙ ΠΑΝΤΑ ΔΙΑΘΕΣΙΜΕΣ.
- CHI** 使用機器前，請閱讀此操作指引，並留意安全守則
操作手冊必須是經常可用的。
- UAE** والامان الوقاية تعليمات ملاحظة نرجوا كما الماكينة بتشغيل البدء قبل التشغيل تعليمات قراءة نرجوا لا بد من وجود تعليمات التشغيل دائما



- D** Keine Bedienung durch Kinder!
GB Children must not operate the machine!
F Pas d'utilisation par un enfant!
NL Geen bediening door kinderen!
I Non lasciare utilizzare il tagliacarte a bambini!
E No dejar que la utilicen los niños!
S Installera maskinen utom räckhåll för barn!
FIN Asentakaa laite lasten ulottumattomiin !
N Installer maskinen utenfor rekkevidde for barn!
PL Dzieciom nie wolno obsługiwać urządzenia !
RUS Не допускайте детей к пользованию аппаратом!
H Gyerekek a gépet nem kezelhetik
TR Makinayı Çocuklar Kullanmamalıdır.
DK Må kun betjenes af voksne
CZ Stroj nesmí být obsluhován dětmi
P As crianças não devem trabalhar com a máquina!
GR ΑΠΑΓΟΡΕΥΕΤΑΙ Η ΧΡΗΣΗ ΑΠΟ ΠΑΙΔΙΑ.
CHI 勿让儿童使用机器!
UAE يجب علي الأطفال عدم تشغيل الماكينة.



- D** Nicht unter das Messer fassen!
GB Do not reach beneath the blade!
F Ne pas passer les mains sous la lame!
NL Niet met de handen onder het mes komen!
I Non toccare la lama nella parte inferiore!
E ¡No tocar debajo de la cuchilla!
S Sträck inte in handen under kniven!
FIN Älä laita kättäsi terän alle !
N Plasser aldri hender ol. under kniven !
PL Nie wkładac rak pod noże!
RUS Избегайте попадания рук под лезвие!
H Ne nyúljon a kés alá!
TR Elinizi bıçağın altına sokmayınız!
DK Stik ikke hænderne ind under knivbladet!
CZ Nesahejte pod ostří nože!
P Não tocar na parte inferior da faca!
GR ΜΗΝ ΑΓΓΙΖΕΤΕ ΤΟ ΚΑΤΩ ΜΕΡΟΣ ΤΗΣ ΛΕΠΙΔΑΣ!
CHI 请勿接触刀具的下方。
UAE لا تصل تحت السكين

- Sicherheitshinweise • Safety precautions
- Consignes de sécurité • Veiligheidsvoorschriften
- Misura di Sicurezza • Normas de Seguridad
- Säkerhetsföreskrifter • Turvallisuusohjeita • Sikkerhetsforskriftene
- Środki bezpieczeństwa • Меры предосторожности

IDEAL 4215



- D** Messer nie lose liegen lassen!
Messer nur mit Messerwechsellvorrichtung oder im Messertransportkasten befördern!
(siehe Seite 25 und 26).
⚠ **Warnung!** Verletzungsgefahr!
- GB** Never leave the blade unattended!
Do not extract or transport the blade without protection!
(See page 25 and 26).
⚠ **Danger!** Risk of injury!
- F** Ne jamais laisser la lame sans protections !
Elle ne doit être démontée qu'à l' aide du dispositif de changement de lame (cf. page 25 et 26), ou transportée dans son étui en bois !
⚠ **Danger!** Risques de coupures !
- NL** Laat nooit de messen alleen achter.
Transporteer de messen niet zonder de houten bescherming (zie pagina 25 en 26).
⚠ **Waarschuwing!** Opgelet voor ongevallen!
- I** Non lasciare mai la lama incustodita. Non rimuovere o trasportare la lama senza protezione. (Vedi pagina 25 e 26).
⚠ **Attenzione!** Rischio di infortunio!
- E** ¡No quitar la cuchilla sin prestar atención. No desmontar no transportar la cuchilla sin protección! (vérase pág. 25 y 26)
⚠ ¡**Advertencia!** ¡Peligro de hacerse daño!
- S** Lämna aldrig maskinen obemannad. Ta inte ur eller transportera kniven utan skydd. (se sid 25 och 26).
⚠ **Skaderisk!**
- FIN** Käsittele terää aina varoen. Älä siirrä tai kuljeta terää ilman suojaa ! (katso sivu 25 ja 26)
⚠ **Loukkaantumisen vaara !**
- N** La aldri kniven ligge ubeskyttet. Ta aldri ut kniven eller transporter den uten beskyttelse (Se side 25 og 26)
⚠ **FARE !** Muligheter for skade !
- PL** Nigdy nie pozostawiac noży bez nadzoru.
Nie wyciągac lub transportowac noży bez oslon!
(zobacz strona 25 i 26).
⚠ **Ryzyko skaleczenia sie!**
- RUS** Не оставляйте открытое лезвие без присмотра! Не пытайтесь извлечь или транспортировать лезвие без специальных мер предосторожности!
(См. страницы 25 и 26)
⚠ **Соблюдайте выше перечисленные правила для избежания травм!**
- H** Soha ne hagyja a kést őrizetlenül!
Ne vegye ki vagy ne szállítsa a kést védőtok nélkül!
(Lásd 25. és 26. oldal)
⚠ **Veszély!** Sérülésveszély!
- TR** Bıçağı hiçbir zaman gözetimsiz bırakmayınız!
Bıçağı muhafazasız olarak yerinden çıkartmayınız veya taşımayınız! (Sayfa 25 ve 26'e bakınız)
⚠ **Dikkat!** Yaralanma riski!



- DK** Knivbladet må aldrig efterlades uden opsyn.
 Forsøg ikke at afmontere eller transportere knivbladet uden beskyttelse! (Se side 25 og 26)
 ⚠ **FARE!** Risiko for legemlig beskadigelse.
- CZ** Nikdy nenechávejte nůž bez krytu.
 Nikdy nevyjímejte nebo neprepravujte nůž bez ochranného krytu (viz. strany 25 a 26)
 ⚠ **Nebezpečí!** Riskujete zranení
- P** Deixar a faca sempre em local seguro!
 Não retirar ou transportar a faca sem protecção!
 (Ver pág. 25 e 26)
 ⚠ **Perigo!** Risco de dano!
- GR** ΜΗΝ ΑΦΗΝΕΤΕ ΤΗΝ ΛΕΠΙΔΑ ΑΝΕΠΙΤΗΡΗΤΗ!
 ΜΗΝ ΑΛΛΑΖΕΤΕ Ή ΜΕΤΑΦΕΡΕΤΕ ΤΗΝ ΛΕΠΙΔΑ ΧΩΡΙΣ
 ΠΡΟΦΥΛΑΞΗ (Δείτε σχετικά στις σελίδες 25 & 26)
 ⚠ **ΠΡΟΣΟΧΗ!** ΚΙΝΔΥΝΟΣ ΤΡΑΥΜΑΤΙΣΜΟΥ!
- CHI** 在没人留意的情况下，请勿离开刀具。
 在没有保护的情况下，请勿取出或运送刀具！（参阅第 25 和 26 页）。
 ⚠ 危险！可引致受伤！
- UAE** لا تترك السكين بدون إهتمام
 لا تخرج أو تنقل السكين بدون حماية (أنظر صفحة 25 و 26)
 ⚠ خطر! التعرض للأذى

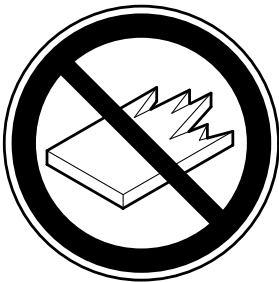

- D** Keine harten und splinternden Materialien schneiden!
- GB** Do not cut hard materials or materials which may splinter!
- F** La coupe de matériaux trop durs ou risquant des projections est interdite !
- NL** Snij geen harde materialen of materiaal dat kan splinteren!
- I** Utilizzare il tagliacarte esclusivamente per il taglio di risme di carta o materiali analoghi!
- E** ¡No cortar materiales duros o materiales que puedan astillarse!
- S** Förstör inte hårt material eller material som kan splittras!
- FIN** Asentakaa laite lasten ulottumattomiin !
- N** Ikke kutt hardt metall eller materiale som kan splintre !
- PL** Nie ciąć twarych materiałóv lub materiałóv, które mogą ulec odprysnieciu!
- RUS** Данный резак не предназначен для резки твердых материалов или материалов, которые могут расщепляться!
- H** Ne vágjon kemény vagy olyan anyagot, amely repedhet!
- TR** Sert veya parçalanabilecek malzemeleri kesmeyiniz!
- DK** Der må ikke skæres i hårde materialer eller i materialer, der kan splintre!
- CZ** Neřežte tvrdý materiál, při kterém mohou ustřelovat ostré úlomky!
- P** Não cortar materiais duros ou materiais que possam lascar!
- GR** ΜΗΝ ΚΟΒΕΤΕ ΣΚΛΗΡΑ ΥΛΙΚΑ Ή ΥΛΙΚΑ ΠΟΥ ΘΡΥΜΜΑΤΙΖΟΝΤΑΙ!
- CHI** 请勿切割坚硬或可裂成碎片物料。
- UAE** لا تقطع الأشياء الصلبة أو الأثنياء التي يتطاير منها شظايا!

IDEAL 4215

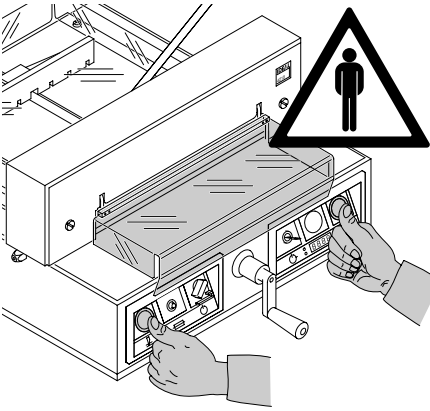

The machine is designed for cutting stacks of paper to a specified size. This machine is constructed for "one-man operation" only!
⚠ Warning! Clips or similar damage the cutting blade.

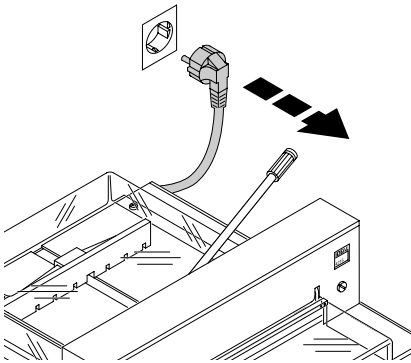

Disconnect from the mains before starting any service work or before removing the panels!

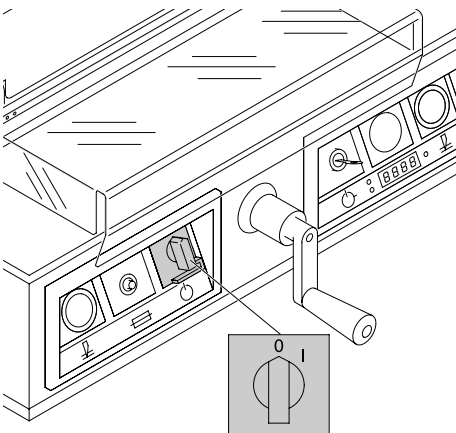

Replacement of blade and cutting stick may be performed only when the main switch is switched off!

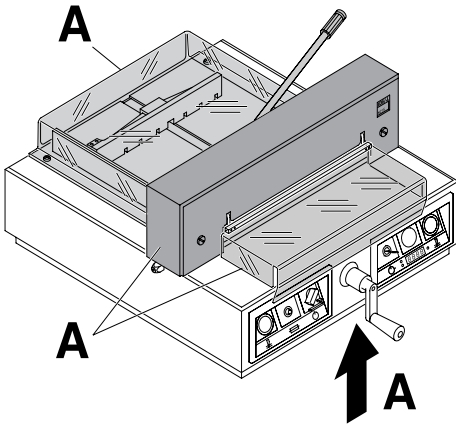

All components which could endanger the operator are covered by a guard!

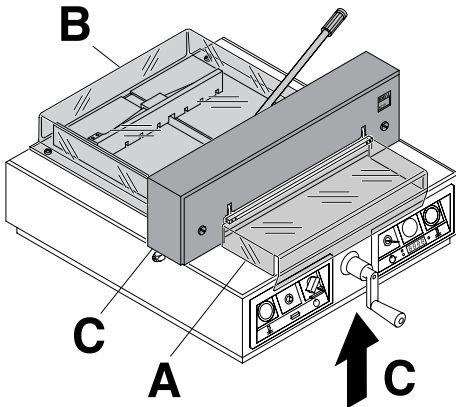

Operating the machine without safety device is forbidden!

- Movable front safety guard (A)
- rear screwed safety guard (B)
- and cover (C)

IDEAL 4215

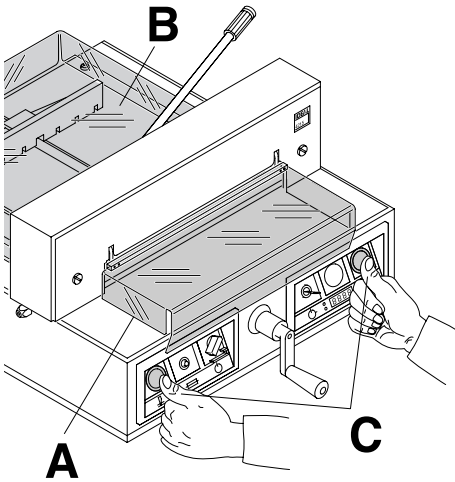

The dangerous cutting movement is safeguarded by a movable guard (A), rear screwed safety guard (B) and a safety two-handed control system! (C)

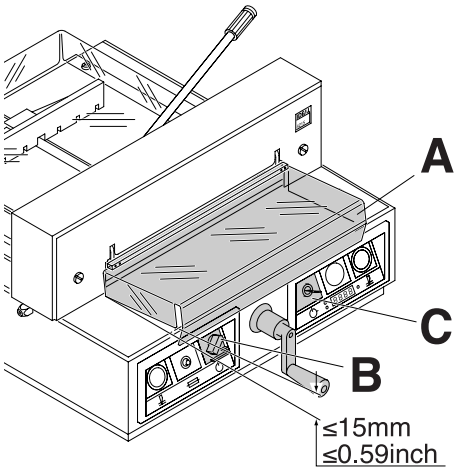

Before working with the machine and after every blade replacement the automatic cut-off function of safety guard (A), (correct if distance between cover and table is $< 15\text{ mm}$) main switch (B) and control panel (C) must be checked.

• Safety precautions •

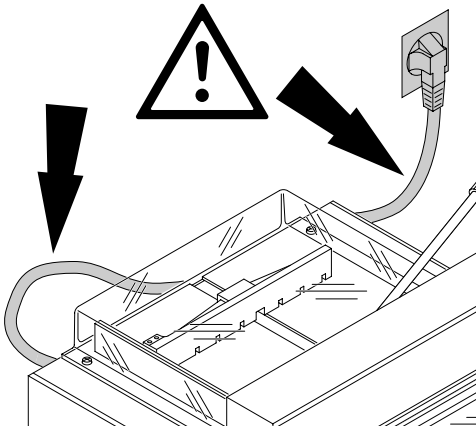

Protect mains cable against heat, oil and sharp edges!

230 V / 10A min
120 V / 15A min

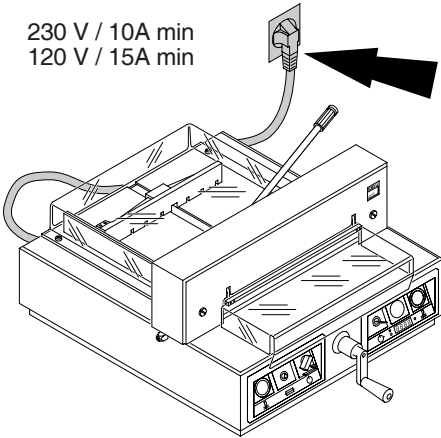

Connect the power cord to a single phase socket.

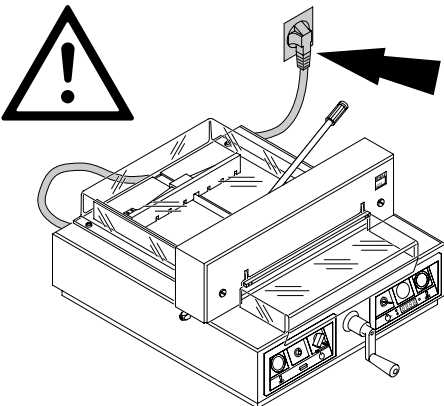

Ensure free access to mains

IDEAL 4215

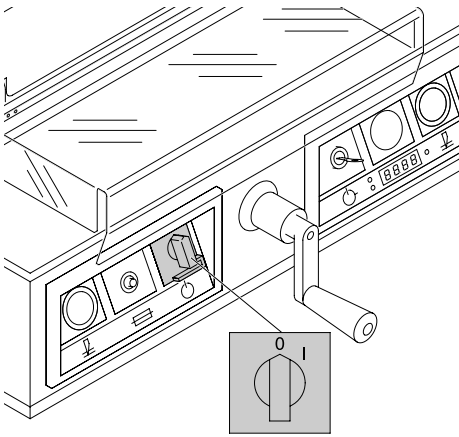

When not in use for a longer period switch off.
(Main switch to "0").

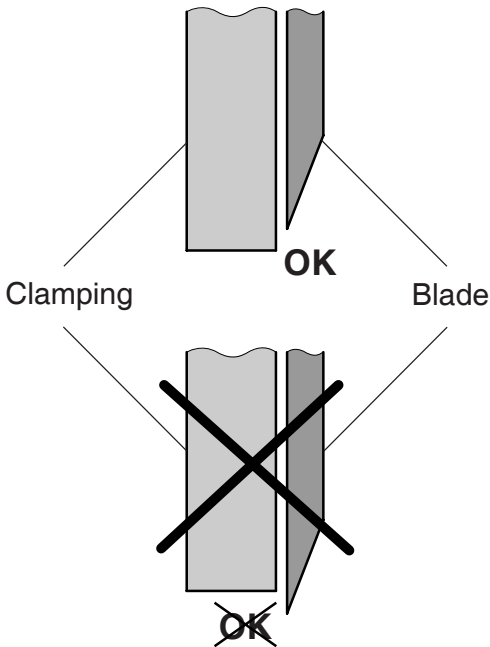

⚠ Danger!
Do not turn main switch to position "0" whilst
blade is moving upwards or downwards!
Risk of injury!

⚠ Danger! Blade must always be covered
by the pressing bar.

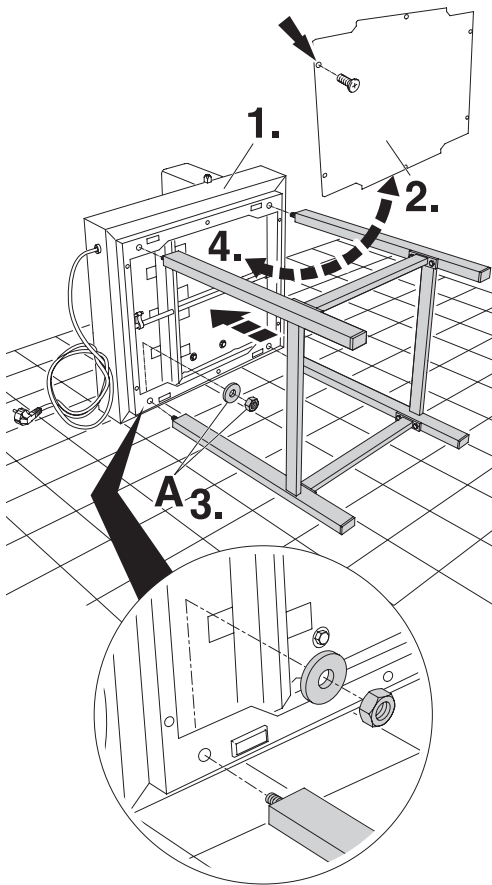

Assembly of stand:

2 strong people are required to lift the machine out of the packaging.

- Lay the machine on the floor side wards (1.).
- Remove the lower cover (2.)
- Place the cutter correctly onto the machine stand. Fit the 4 washers and tighten the 4 hexagon nuts with a spanner (3.).
- Screw on the lower cover (4.)
- Install the machine.

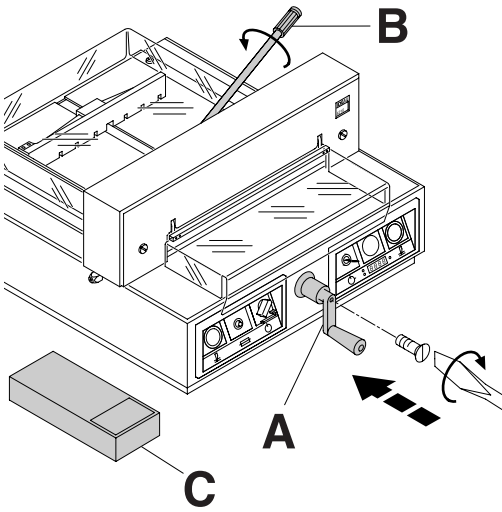

Plug into socket.

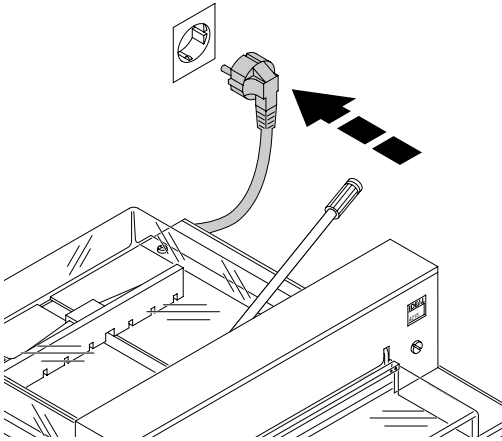

IDEAL 4215

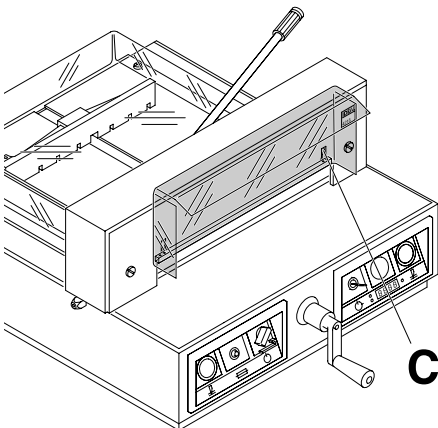
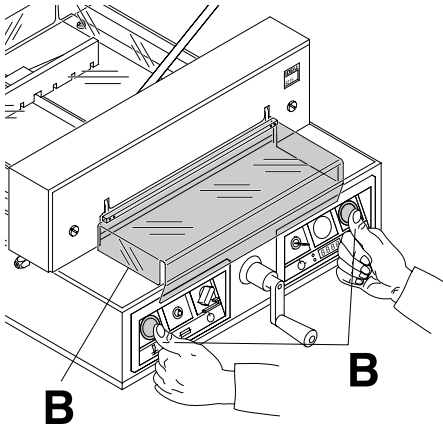
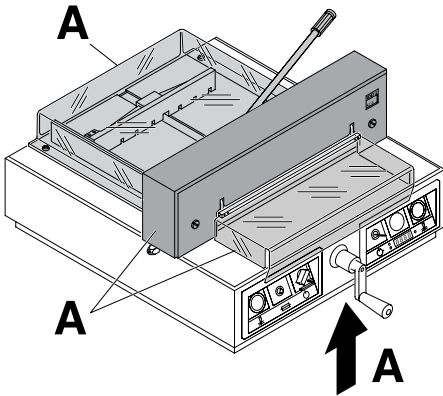

It is forbidden to operate the machine if the operating and safety instructions have not been understood. Please check the safety devices are functioning and complete before use.

- All covers have to be mounted (A).
- The release for cutting is allowed only if the cover is closed and the two-hand safety device is operated at the same time (B).
- The front cover should not close by itself. Tighten the hexagonal recess screw right (C).

We recommend you keep a record of your test results.

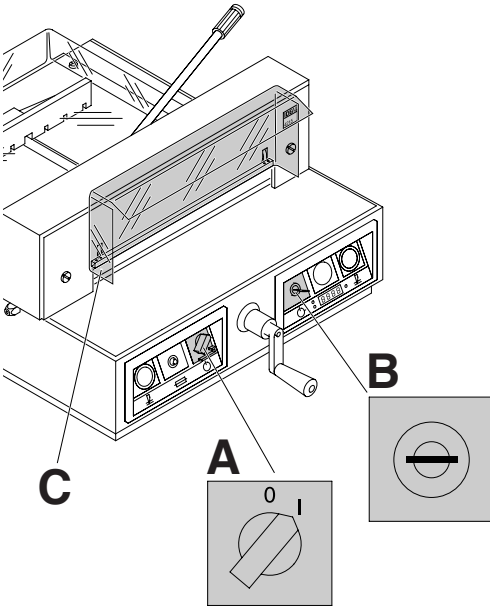

Position the main switch "I" (A)
Insert the key the control system and move it to
the right (B). Open the safety guard (C). The
machine is now ready for use.

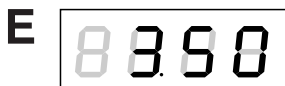
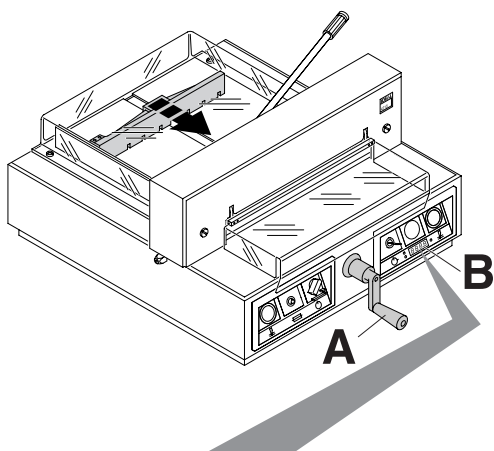

The measurement is set with the backgauge crank. (A) The symbol – rotary direction – \curvearrowright moves to the right on the display (B) (see picture C). The rotary direction of the backgauge crank (A) is indicated on the right. Keep turning the backgauge crank to the right until a measurement appears (see picture E). The reference position is reached. The cutting size can now be set with the handle (A).

If the backgauge is right at the front the symbol – rotary direction – \curvearrowleft will move to the left (see picture D). Turn the backgauge crank to the left until the rotary direction appears on the right \curvearrowright in the display (see picture C). Afterwards turn the backgauge crank to the right until a measurements appears (see picture E). The reference position is reached. The cutting size can now be set with the handle (A).

Measurement is shown on the display in inches or cm (B).

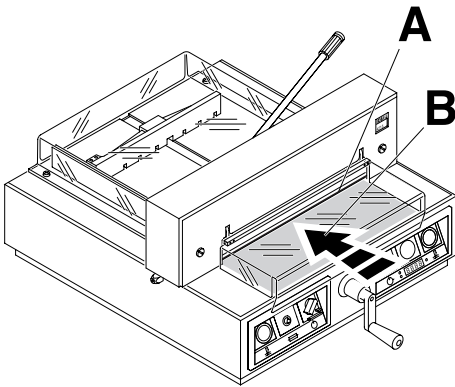

Optical cutting red line (A). Blade cuts on the front edge (B) of the light beam.
(Only use when no exact cut is required).

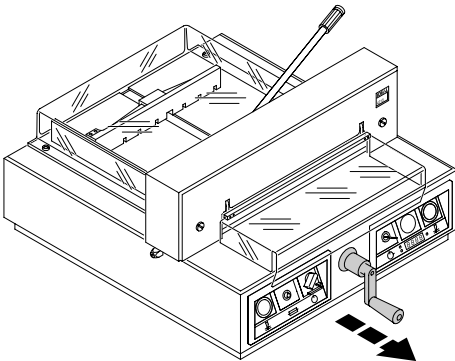

Pull out the handle to avoid the measurement being wrongly adjusted.

IDEAL 4215

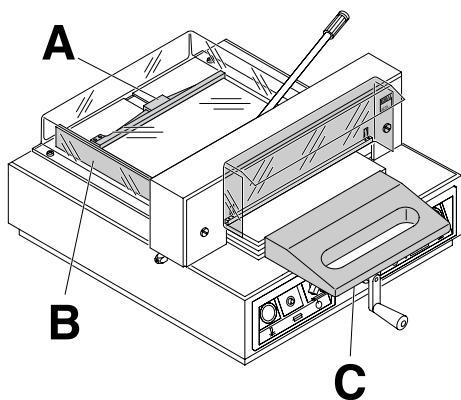

Position the paper on the backgauge (A) and the side lay (B). To move paper stacks, please use the paper knock-up block (C). Run backgauge to the front for turning the paper stack.

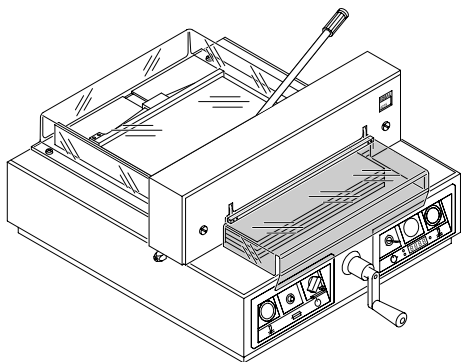

Close the safety guard.

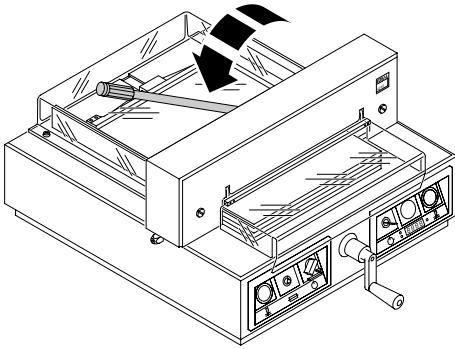

Before every cut the lever must be moved to the left and tightened with light pressure.

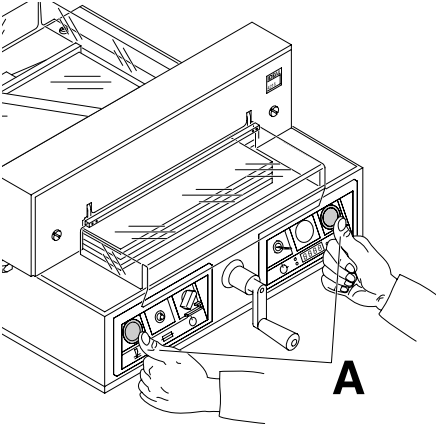

Cutting activation:

Press both buttons of the two-handed control system (A) simultaneously and keep them pressed until the paper is completely cut.

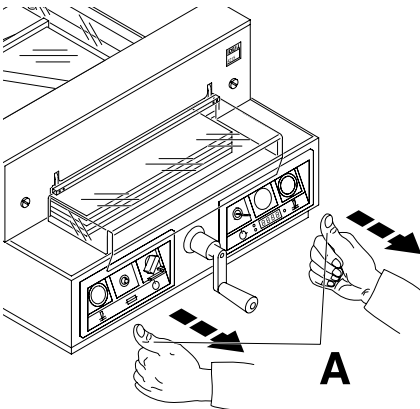

To interrupt or stop cutting:

To interrupt or stop cutting, release both buttons (A) of the two-hand control.

IDEAL 4215

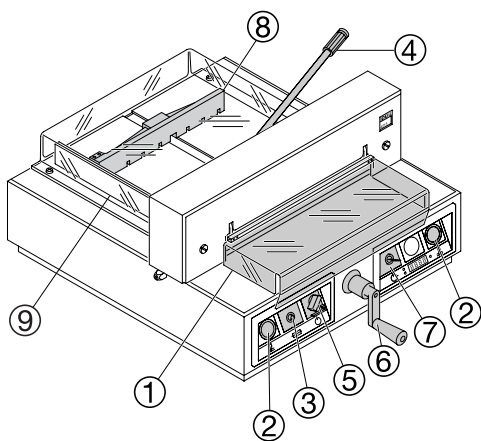

Operating elements

- ① - Front safety guard
- ② - Safety two-handed control system
- ③ - Overload switch blade drive
- ④ - Clamping
- ⑤ - Main switch
- ⑥ - Crank handle for backgauge setting
- ⑦ - Key switch
- ⑧ - Backgauge
- ⑨ - Side lay left
- ⑩ - Display cutting size (cm or inch)
- ⑪ - Changeover cm/inch
- ⑫ - Measuring unit (cm or inch)

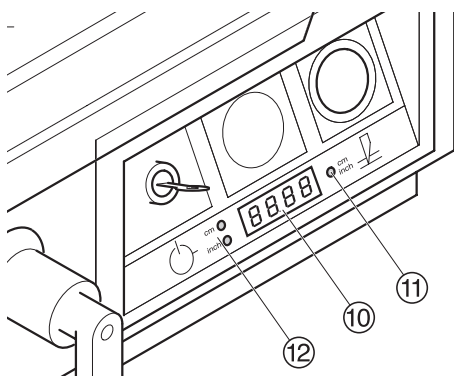

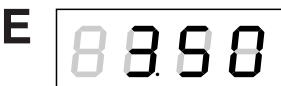
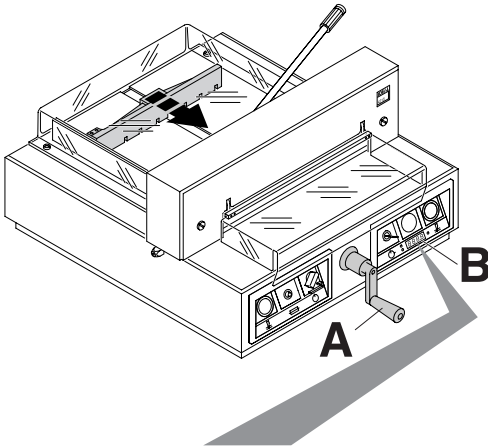
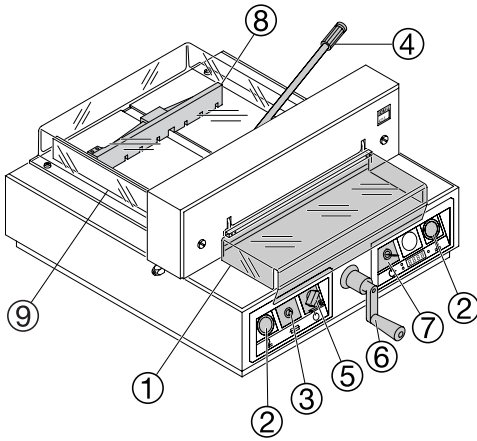

Start machine

- Main switch ⑤ to position "I", insert the key ⑦ for the control panel and turn it to the right. Open the front safety guard ①.

⚠ Warning!

Before cutting a measurement please check if the correct scale (cm or inch) is set.

Display in cm or inch

- Press $\frac{cm}{inch}$ → Display changes between cm and inch. For information on how to store see page 20, picture below left.
- The measurement is set with the backgauge crank. **(A)** The symbol – rotary direction – \curvearrowright moves to the right on the display **(B)** (see picture **C**). The rotary direction of the (backgauge crank **(A)**) is indicated on the right. Keep turning the backgauge crank to the right until a measurement appears (see picture **E**). The reference position is reached. The cutting size can now be set with the handle **(A)**.

If the backgauge is right at the front the symbol – rotary direction – \curvearrowleft will move to the left (see picture **D**). Turn the backgauge crank to the left until the rotary direction appears on the right \curvearrowright in the display (see picture **C**). Afterwards turn the backgauge crank to the right until a measurement appears (see picture **E**). The reference position is reached. The cutting size can now be set with the handle.

The measurement scale in cm or inch γ has a LED display.

For information on how to store see page 20, picture below left.

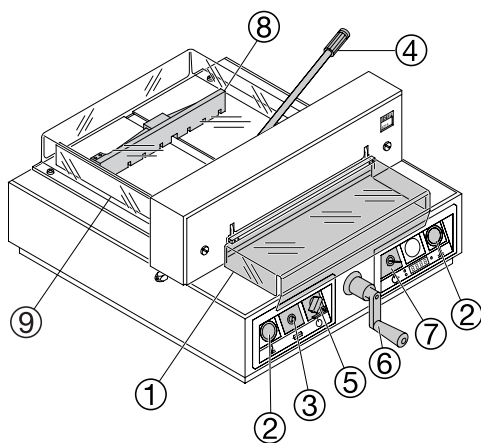

Cutting to specified dimensions

- The cutting size can now be set with the handle ⑥.
- Insert paper and move by means of the stacking angle to the backgauge ⑧ and side lay on the left ⑨.
- Move the pressing lever ④ to the left by a slight swing.
- Close the front safety guard ①.
- Release the cut.

Cut according to markings

- Adjust the backgauge with the crank handle ⑥ to the back.
- Insert paper and move by means of the stacking angle to the backgauge ⑧ and side lay on the left ⑨.
- Turn crank handle ⑥ to the right until the marking on the paper to be cut is below the cutting line indicator.
- Move the pressing lever ④ to the left by a slight swing.
- Close the safety guard ①.
- Release the cut.

Cutting activation

⚠ Warning!

- Run backgauge to the front for turning the paper stack.
- Do not interrupt the upward movement of the blade by performing switching procedures.
- Close the front safety guard ①.
- Blade must always be at the top and be covered by the clamp. Do not touch the blade - **risk of injury!** (see security information on page 31).

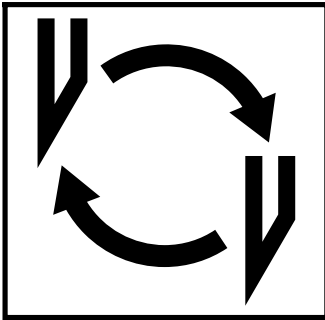

If the cutting quality decreases:

- Check the cutting depth (see page 31).
- Check the cutting stick (see page 24).
- Replace or grind the blade (see page 23 - 31).

The blade cannot be ground if the blade height is less than 35 mm/1,38 inches. A new blade must be used.

Purchase the new blade from Krug & Priester, D -72336 Balingen only.

The blade may only be ground by a qualified workshop or from the manufacturer Krug & Priester, D -72336 Balingen.

⚠ Danger! Risk of injury!

The blade is extremely sharp. Do not extract or transport the blade without protection. Changing the blade may only be performed by trained staff.

IDEAL 4215

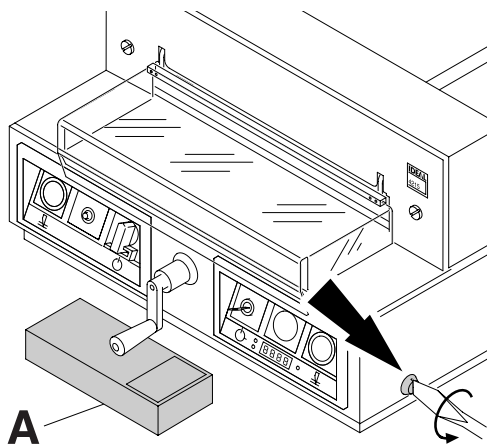

Turn the blade depth adjustment screw to the left until it stops (screwdriver found in tool set (A)).

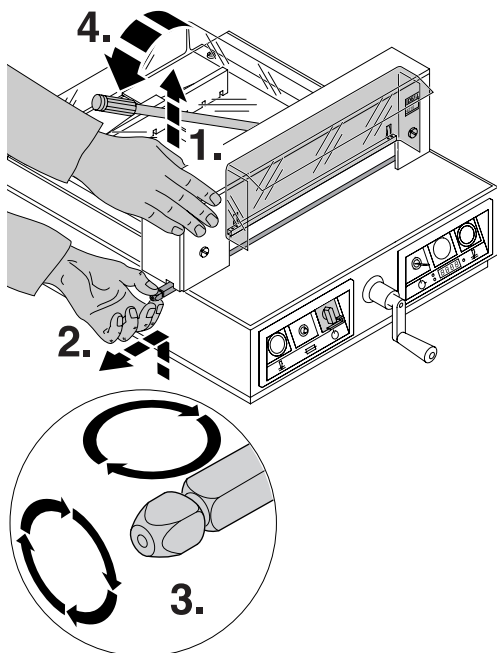

Cutting stick replacement :

- Lift the cover (1.)
- Lift the cutting stick by hand and pull it out.(2.)
- If needed the cutting stick can be turned or exchanged. (The cutting stick can be used eight times). (3.).

After exchanging the cutting stick **close the clamp by moving the clamp lever to the left (4).**

• Blade and cutting stick replacement •

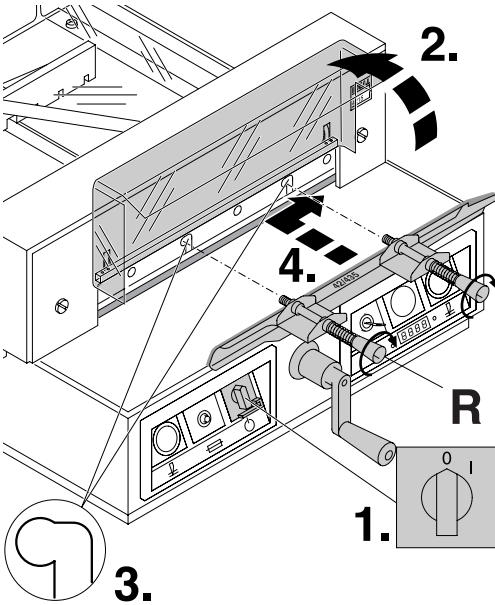

Position the main switch to "0" (1.)
Open the safety guard (2.). Remove the 2 blade screws on the elongated holes (3.). Then put the blade changing tool (R) into place and fasten it to the blade (4.).

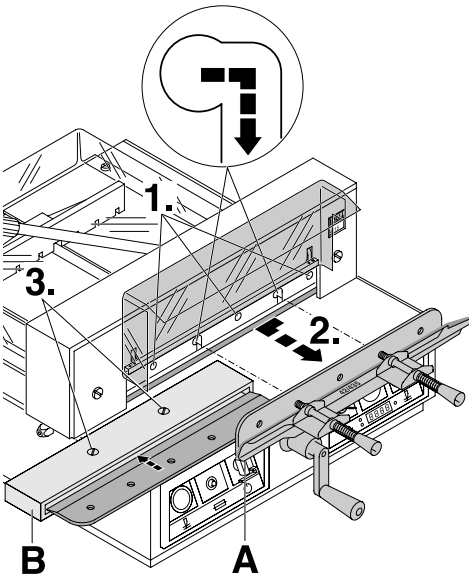

Remove the remaining 3 screws (1.).
Push the blade and blade changing tool (A) to the right and lower to remove (2.)
Place the blade into the blade carrier (B) and screw it into place (3.).

IDEAL 4215

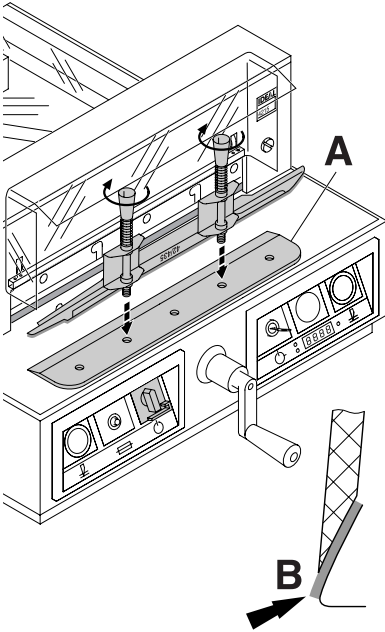

Take the exchange blade carefully out of the blade box and screw it to the blade changing tool (A)

- blade must be covered! (B).

⚠ **Danger! Risk of injury!**

• Blade and cutting stick replacement •

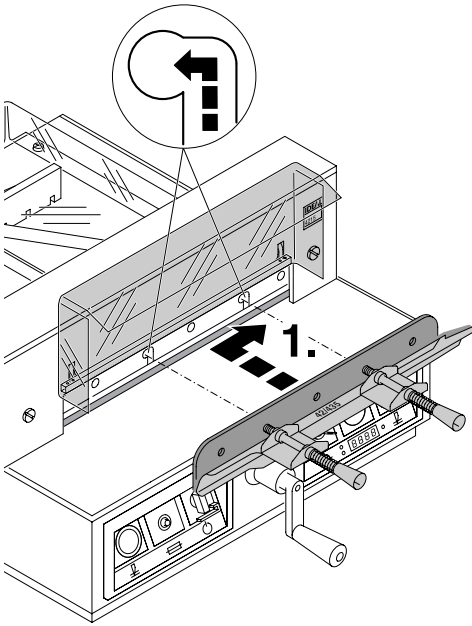

Place the blade to be exchanged, using the blade changing tool, into the blade carrier and push to the top and to the left.(1.) (see picture **A**) while doing so push both springs back.

It is only necessary to push back the springs if a polished blade is to be exchanged. (see picture **B**).

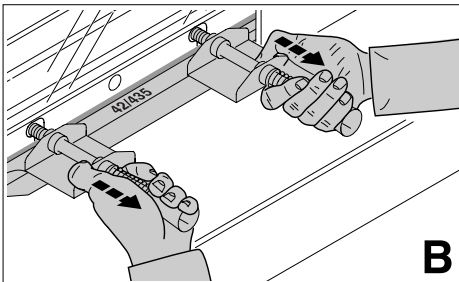
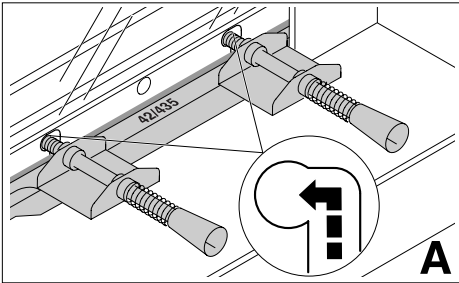

IDEAL 4215

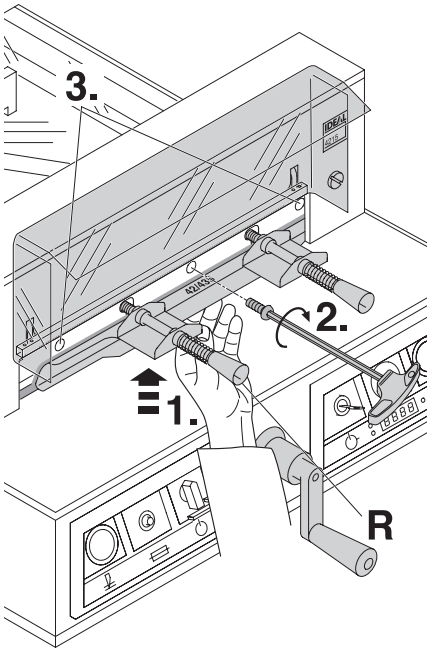

Push the blade changing tool to the top with your hand (1.). First, lightly tighten the middle blade screw with your other hand (2.) and then both blade screws left and right (3.). Remove the blade changing tool (R) (unscrew the grips).

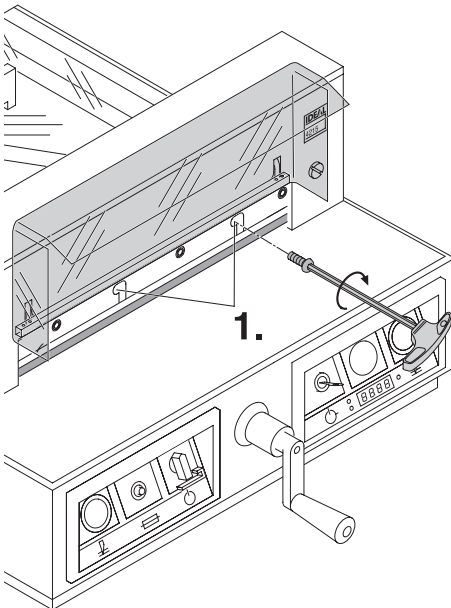

Lightly tighten the 2 blade screws on the elongated holes (1.).

• Blade and cutting stick replacement •

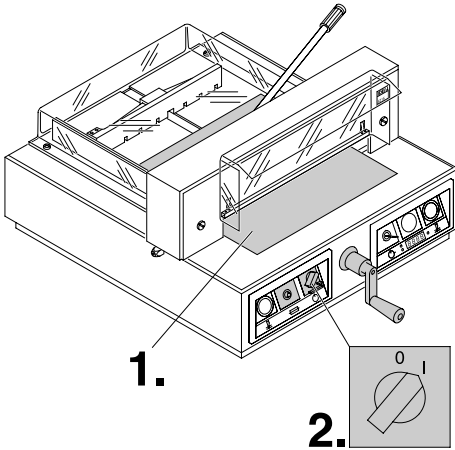

Remove all tools and distribute paper along the entire cutting length (1.).
Turn main switch to position "I" (2.).

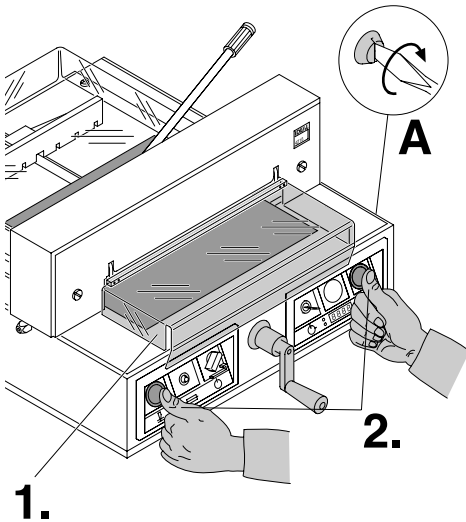

Close the safety guard (1.) Lower the blade by pressing both cutting buttons (2.)
If the last sheet of paper is not completely cut, gradually turn the knob for blade-depth adjustment (A) $\frac{1}{4}$ turn to the right until the paper is cut along the entire length.
(1 turn = 1,5 mm)

IDEAL 4215

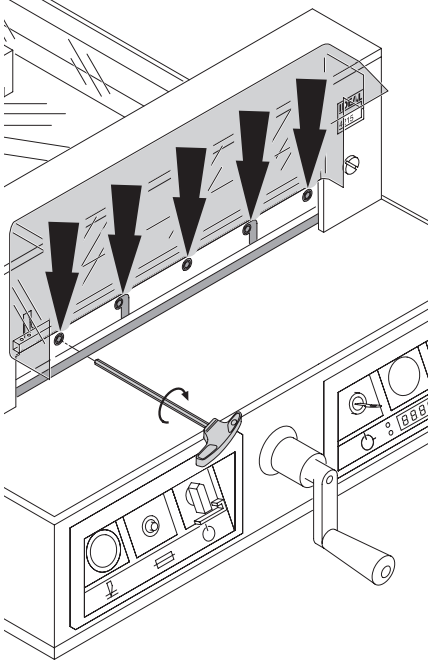

Tighten all 5 blade screws.

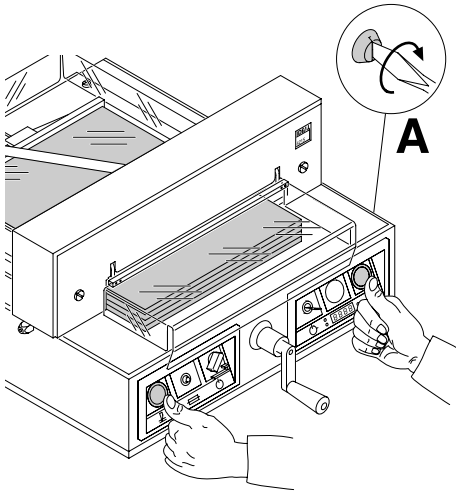

Paper cutting test. If the last sheet or several sheets are not completely cut, gradually turn the knob for blade depth adjustment (A) $\frac{1}{4}$ turn to the right until the paper is cut along the entire length. Do not set too low as blade will become blunt sooner.

⚠ Danger! Do not turn main switch to position "0" whilst blade is moving upwards or downwards!
Risk of injury!

⚠ Danger! Blade must always be covered by the pressing bar (see picture below on the left).

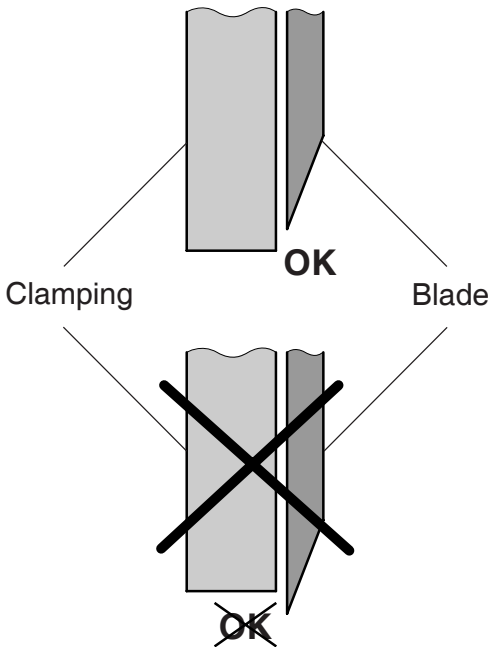

IDEAL 4215

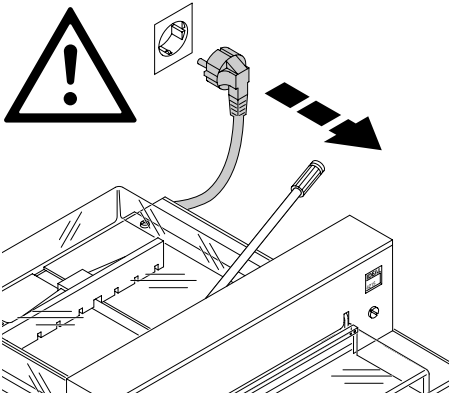

Maintenance work may only be performed by trained staff.

⚠ Danger! Disconnect the mains before starting any service work or before removing the cover.

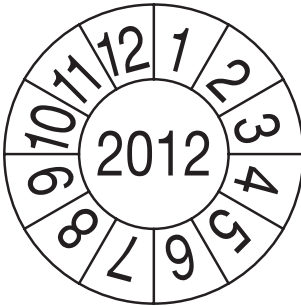

Safety test

The safety regulations are according to the regulations of the country where the cutting machine is operated. The manufacturer recommends a safety check is made every 5 years by an authorised service team.

 = Greasing points on the machine.

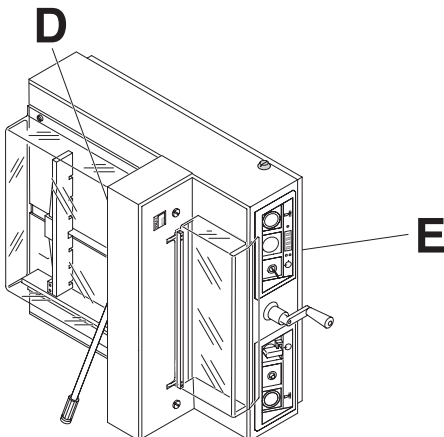
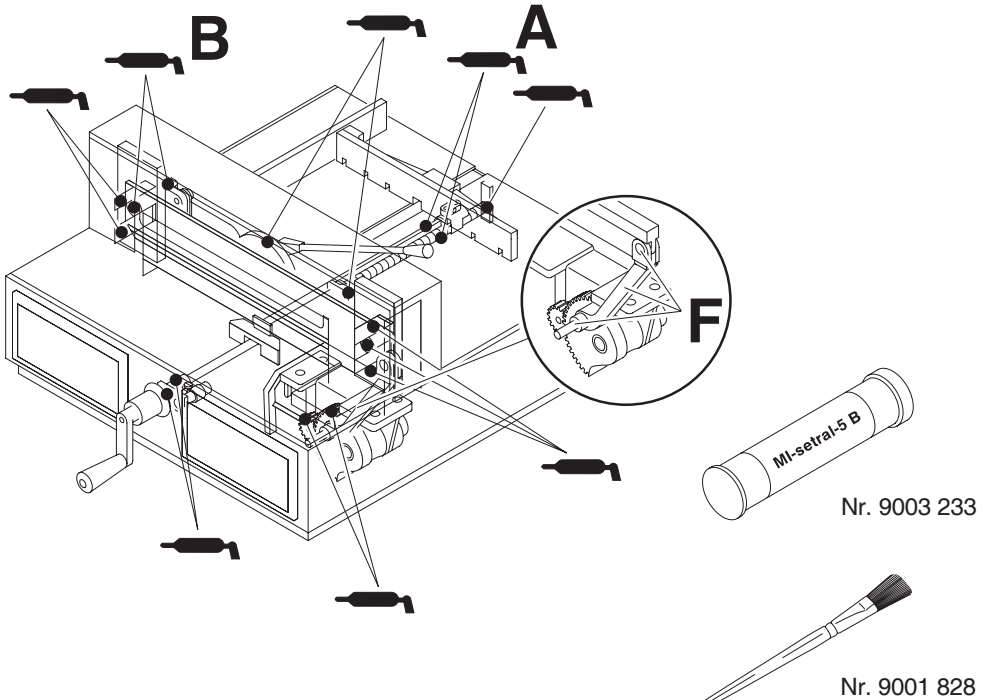

Grease the backgauge (A) control weekly.
(Use non-resinous grease).
Grease the remaining parts (B) twice a year
(see picture).

⚠ Danger! Disconnect the mains before starting any service work or before removing the cover.

Put the machine on its left side.

⚠ Danger! of tilting!

Remove cover (C) and lower panel (D) (tools in tool set).

- Remove remaining paper
- Grease the machine
- **Check the two joining bolts and pushing bar for wear. (F). If necessary inform your service personnel.**
- Mount the machine.

IDEAL 4215



Machine does not function!

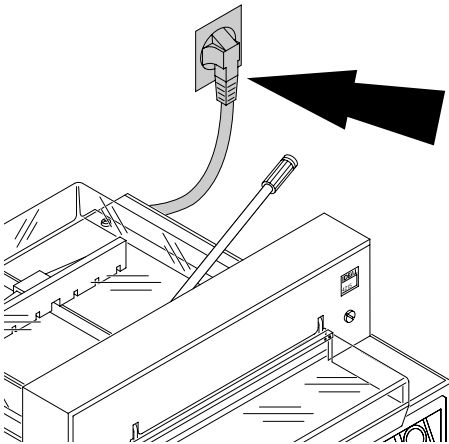

Is the machine plugged in?

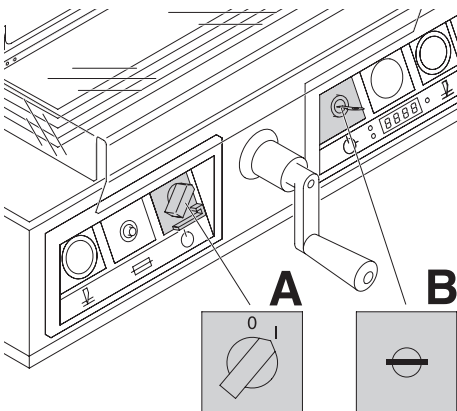

Main switch to position "I"? **(A)**
Control system activated? **(B)**
(Turn key to the right)
Release a cut see page 19.

• Possible malfunctions •

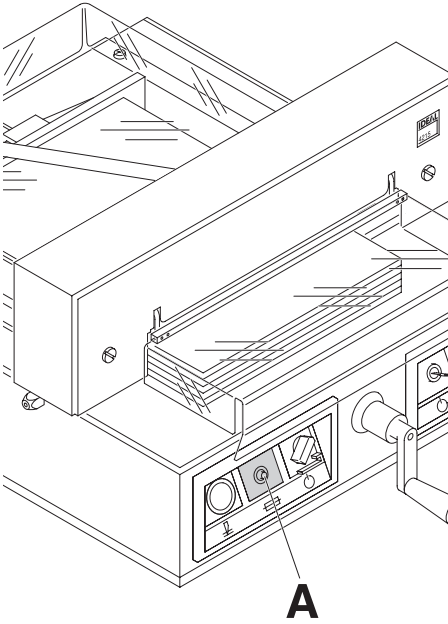

Machine turns off:

- Machine overloaded
Safety button (A) ejects.
Allow 1 minute cooling time and reset the safety button (A).
- Machine blocked
- Blade is blunt
Eliminate the cause, and push the safety button (A).

IDEAL 4215

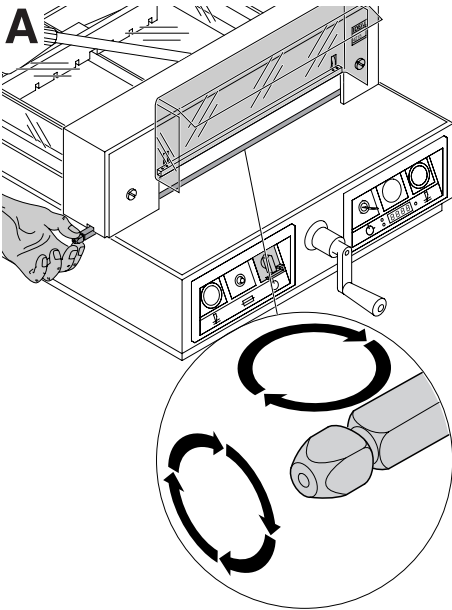

Does not cut through the last sheet:

- Turn or turn around the cutting stick (A), readjust the blade by means of the blade adjusting knob (B). (See page 31).

Poor cutting quality or blade stays in the paper stack.

- change the blade (C) (see page 23 - 31).

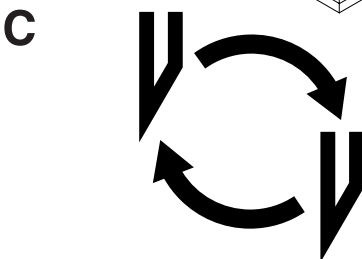
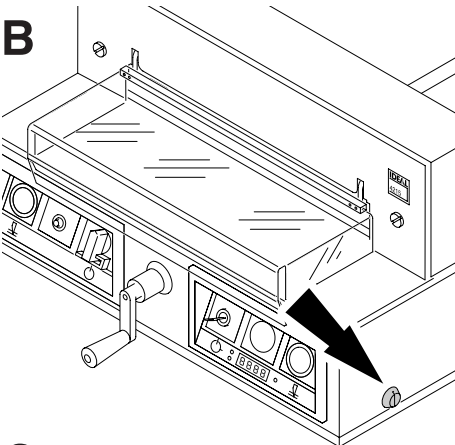

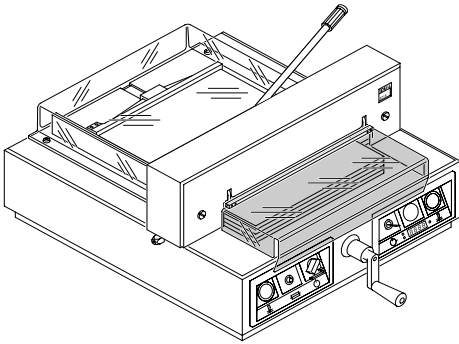

Cut cannot be made.

- If cover is open:
close it.
- If cover is closed:
open and re-close it. (Security check).

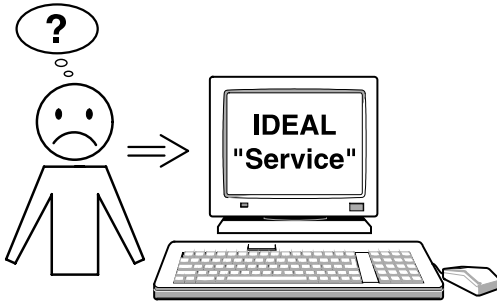

Motor runs but blade does not move downwards.

- Security brake has been activated!

Inform the service team!

None of the above mentioned methods helped to solve the problem:

Contact Service Team under

- www.ideal.de → "Service"
service@krug-priester.com

IDEAL 4215

Recommended Accessories:

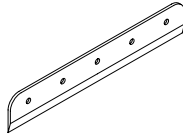

Blade Nr. 9000 121

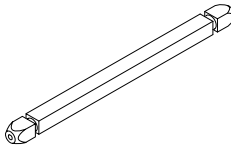

Cutting stick (6 pieces) Nr. 9000 221

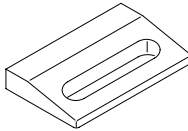

Paper knock-up block Nr. 9000 520 ¹

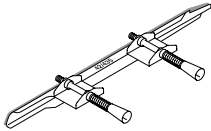

Blade changing tool Nr. 9000 517 ¹

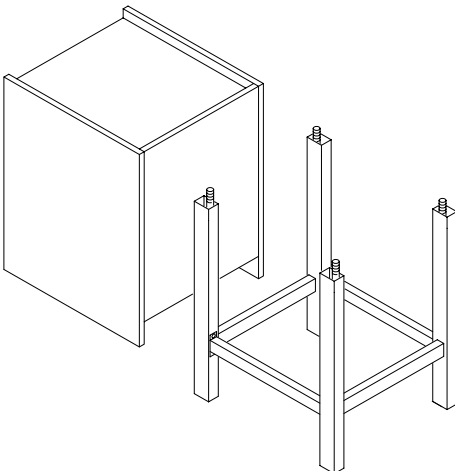

Cabinet Nr. 4215 1100

Stand Nr. 4205 1100

¹ Included in delivery.

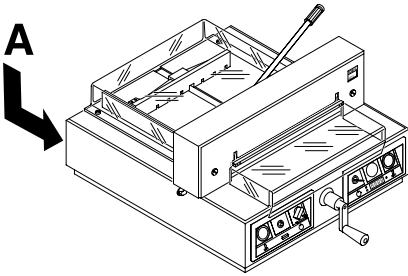

Technical data:

- Power supply: 230V/50Hz/0,45KW, 120V/60Hz/0,45KW
- Cutting height: 40 mm
- Sound level: EN 13023: < 70 dB (A)

The exact technical specifications can be found on the technical specifications sticker (A) on the machine. A wiring diagram is found in the electrical switch box.

	Cutting-length mm	Table-depth mm	Minimum space requirement (B X T X H) mm	Weight kg
IDEAL 4215	430	390	640 x 695 x 355/*/**	78 /*/**

* with stand 1044mm/E, 1044mm/EP
90 kg/E, 94 kg/EP

** with cabinet 1044mm/E, 1080mm/EP
112 kg/E, 116 kg/EP

IDEAL 4215



This machine is approved by independent safety laboratories and is in compliance with the EC-regulations 98/37/EG, 2006/95/EG and 2004/108/EG.

Sound level information:

The sound level is < 70 db (A) as defined by EN 13023.

Subject to alteration without notice.



I.T.E. Listed 802 D

QUALITÄTSMANAGEMENTSYSTEM



DQS-zertifiziert nach
DIN EN ISO 9001 : 2000
Reg.- Nr. 1489 QM

D	EG-KONFORMITÄTSERKLÄRUNG
GB	EC-declaration of conformity
F	Déclaration de conformité CE
NL	EG-verklaring van overeenstemming
I	Dichiarazione CE di conformità
E	Declaración CE de conformidad

- Hiermit erklären wir, daß die Bauart von

- Herewith we declare that
- Par la présente, nous déclarons que
- Hiermede verklaren wij, dat de in de handel gebrachte machine
- Si dichiara che il modello della
- Por la presente, declaramos que la

4215

- folgenden einschlägigen Bestimmungen entspricht

- complies with the following provisions applying to it
- sont conformes aux dispositions pertinentes suivantes
- voldoet aan de eisen van de in het vervolg genoemde bepalingen
- è conforme alle seguenti disposizioni pertinenti
- satisface las disposiciones pertinentes siguientes

98/37/EG; 2006/95/EG; 2004/108/EG

- Angewendete harmonisierte Normen insbesondere

- Applied harmonised standards in particular
- Normes harmonisées utilisées, notamment
- Normas armonizadas utilizadas, em particular
- Norme armonizzate applicate in particolare
- Gebruikte geharmoniseerde normen, in het bijzondere
- Normas armonizadas utilizadas particularmente

**EN 60204-1; EN 1010-1; EN 1010-3; EN ISO 61000-3-2; EN ISO 61000-3-3;
EN ISO 12100-1; EN ISO 12100-2; EN 294; EN 954-1; EN 13023;**

Krug & Priester GmbH u. Co KG
72336 Balingen, Germany

01.04.2007
Datum

Wolfgang Priester
- General Manager -

IDEAL 4215

Remarks:



Document Shredders

Trimmers and Guillotines

